

## 2FHC0240 Product Data Sheet

### Overview

2FHC0240 series product is a driver core designed for Infineon easy series or other similar packaged SiC modules. Adopts vertical connector and reinforced insulation design to meet UL 61800 standard. Modules up to 2000 V are supported.

#### Core features:

- Reinforced insulation design for modules up to 2000 V
- UVLO
- Miller clamping
- Intelligent fault feedback

#### Typical applications:

- SST (Solid State Transformer)
- ESS PCS
- Motor drive

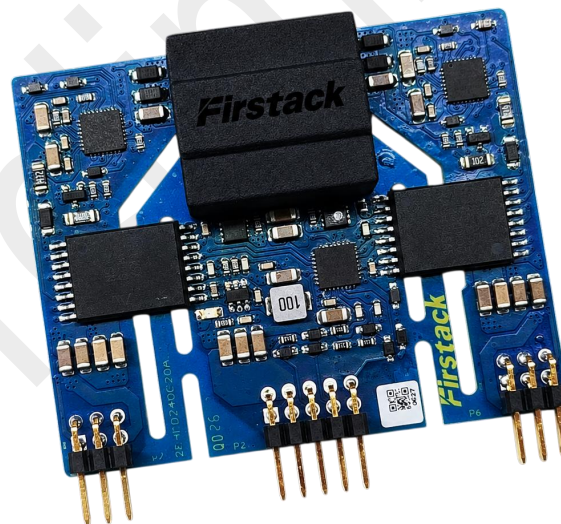

Figure 1 2 FHC0240

The product is still in the sample stage, and the final product form and style shall be subject to the official specification. All data in this specification are actually measured data, but there is still the possibility of change.

Functional framework diagram

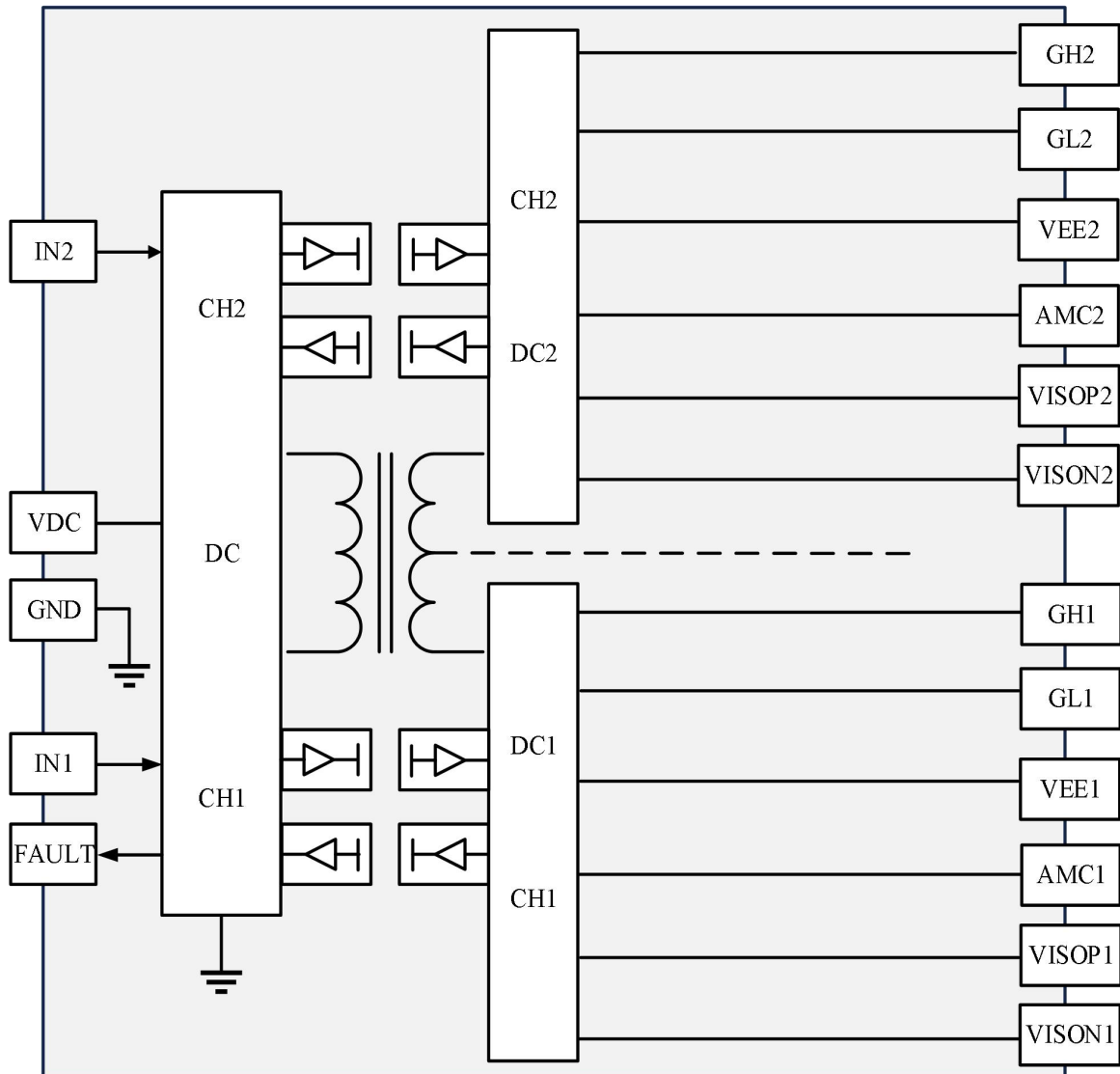

Figure 2 Functional framework diagram

Drive layout

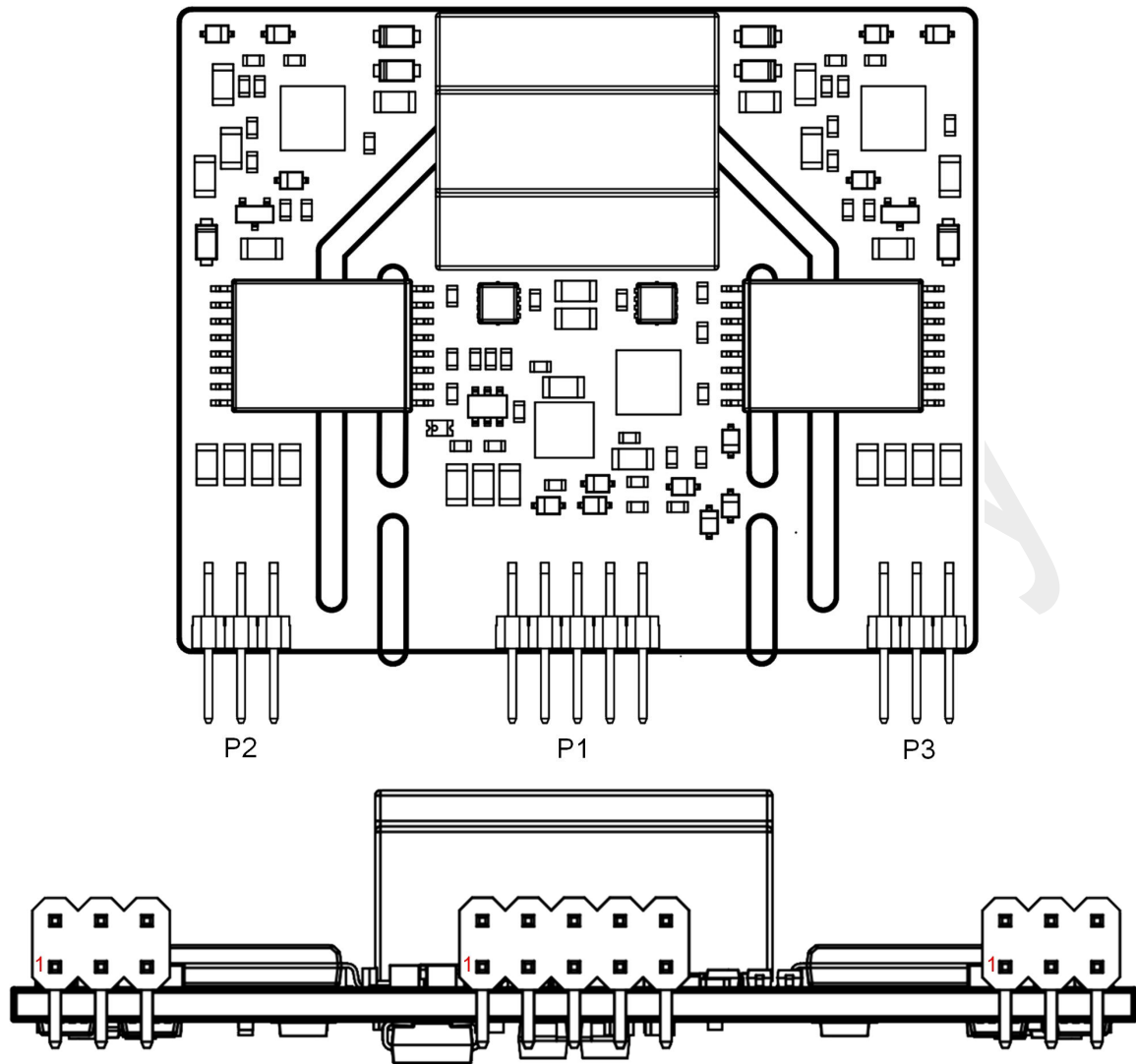
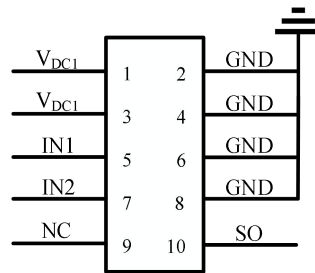

Figure 3 Interface Definition Diagram

### Primary P1 pin definition



#### Pin definitions

Pin	Definition	Function	Pin	Definition	Function
1	V <sub>DC</sub>	15 V input	2	GND	Primary side reference ground
3	V <sub>DC</sub>	15 V input	4	GND	Primary side reference ground
5	IN1	Channel 1 PWM Input	6	GND	Primary side reference ground
7	IN2	Channel 2 PWM Input	8	GND	Primary side reference ground
9	NC	NC	10	SO	OD fault output (external pull-up is required)

### Secondary P2/P3 Definition

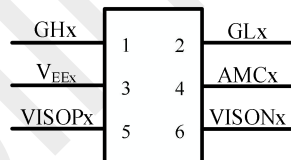

#### Pin definitions

Pin	Definition	Function	Pin	Definition	Function
1	GH <sub>X</sub>	Channel X open signal	2	GL <sub>X</sub>	Channel X Shutdown Signal
3	V <sub>EE X</sub>	Channel X Source (Ground Reference)	4	AMC <sub>X</sub>	Miller clamp signal
5	VISOP <sub>X</sub>	Power supply positive voltage	6	VISON <sub>X</sub>	Negative pressure of power supply

Note: IN1 to P2, IN2 to P3

**Maximum/Minimum Values**

Parameter	Description	Min	Max	Unit
Supply voltage $V_{DC}$	To the ground	0	15.5	V
Supply current $I_{DC}$	Full load 2 W		0.51	A
Max. output current	@85°C	-40	40	A
Output power per channel (Note 1)	@70°C		3	W
	@85°C		2	W
Switching frequency (Note 2)	$V_{GS}=18V/-4V$ ; $Q_g=0.9\mu C$ @85°C		100	kHz
Test voltage (50Hz/min)	Primary to secondary	5000		$V_{RMS}$
Operating voltage	Maximum allowed $V_{DS}$		2000	$V_{DC}$
Operating temperature		-40	85	°C
Storage temperature		-40	85	°C

**Recommended working conditions**

Parameter	Description	Min	Typ	Max	Unit
Supply voltage $V_{DC}$	To the ground	14.5	15	15.5	V
Supply current $I_{DC}$	Without load		0.09		A
Input signal (PWM to GND)		0	15	$V_{DC}$	V

**Electrical parameters****Gate drive parameters (Note 3)**

Parameter	Description	Min	Typ	Max	Unit
$V_{GSon}$	Turn on (ON)		18		V
$V_{GSoff}$	Turn off (OFF)	-4.8	-4	-3.5	V

**Input/Output Logic**

Parameter	Description	Min	Typ	Max	Unit
Turn on threshold (PWM to GND)	Driver IC on/off threshold, Note 4		7.8		V

Turn off threshold (PWM vs. GND)		5.1	V
Fault output SOx	Io<10mA	OD output	
Mode selection	Direct mode (default)	Set by software without additional peripheral circuit	
	Half-bridge mode	Set by software without additional peripheral circuit	

**Miller clamping**

Parameter	Description	Min	Typ	Max	Unit
Miller Clamping Delay (Note 5)	Delay time for Miller clamp to start after drive starts to shut down	(Configurable)	350	(Configurable)	ns
Clamping voltage (Note 6)			V <sub>SS</sub>		V

**UVLO**

Parameter	Description	Min	Typ	Max	Unit
Primary undervoltage threshold			12		V
Secondary undervoltage threshold	Positive undervoltage		12.5		V

**Time characteristics**

Parameter	Description	Min	Typ	Max	Unit
Turn on delay	(Note 7)		704		ns
Turn off delay	(Note 8)		690		ns
Rise time	(Note 9)		26.8		ns
Fall time	(Note 10)		16.8		ns
Fault classification time	(Note 11)		Distinguish according to the type of fault		ms

**Electrical insulation**

Parameter	Description	Min	Typ	Max	Unit
Creepage distance (Note 12)	Primary side to secondary side		12.5		mm
	Secondary to secondary side		10		mm
Clearance (Note 12)	Primary side to secondary side		9		mm

	Secondary to secondary side	6.5	mm
PDEV	IEC 61800	2700	Vac

Unless otherwise specified, all data are based on + 25 °C ambient temperature and  $V_{DC}= 15V$ .

Note:

1. The output power of the power supply needs to include the static power consumption of the drive;
2. The switching frequency depends on the Qg of the ambient temperature and the module, and can be estimated according to the formula  $f = P/Qg * Vgs$ ;
3. The positive and negative voltage of the gate can be changed by software. Please refer to the SiC driver application manual for details.
4. The recommended amplitude of the input PWM signal is 15 V. This threshold is for a 15 V signal. If a 5V input signal is used, please contact the technical support.
5. 350ns is the time from the start of the drive shutdown to the start of the Miller clamp, which is a delay that can generally meet the practical application. For the delay adjustment required for special needs or operating conditions, please contact the relevant technical support;
6. Miller clamping stabilizes the gate voltage at a negative drive voltage ( $V_{SS}$ ), the magnitude of which depends on the configuration of the gate output;
7. Turn-on delay: the time required from the primary side receiving the rising edge of the input PWM signal to the secondary side responding to the rising edge of the output gate;
8. Turn-off delay: the time required from the primary side receiving the falling edge of the input PWM signal to the secondary side responding to the falling edge of the output gate;
9. Rise time: time from 10% of the gate-off voltage to 90% of the gate-on voltage;
10. Fall time: the time from 90% of the gate-on voltage to 10% of the gate-off voltage;
11. When the drive is normal, the SOx output is high level, and it becomes low level in case of fault. The fault type can be distinguished by the low level duration: the secondary side undervoltage fault is 20 ms, the primary side undervoltage fault is 40 ms, and the short circuit fault cannot be detected;
12. Creepage and electrical distance shall be designed according to IEC61800-5-1-2007, and shall meet the reinforced insulation requirements of pollution level 2 and overvoltage level II at an altitude of less than 2km;
13. The partial discharge test result does not represent the transformer's maximum partial discharge extinction voltage; instead, it is a test conducted according to the voltage level of the module matching 2FHC0240. The transformer's own PDEV is up to 2800 Vac.

Mechanical Dimensions

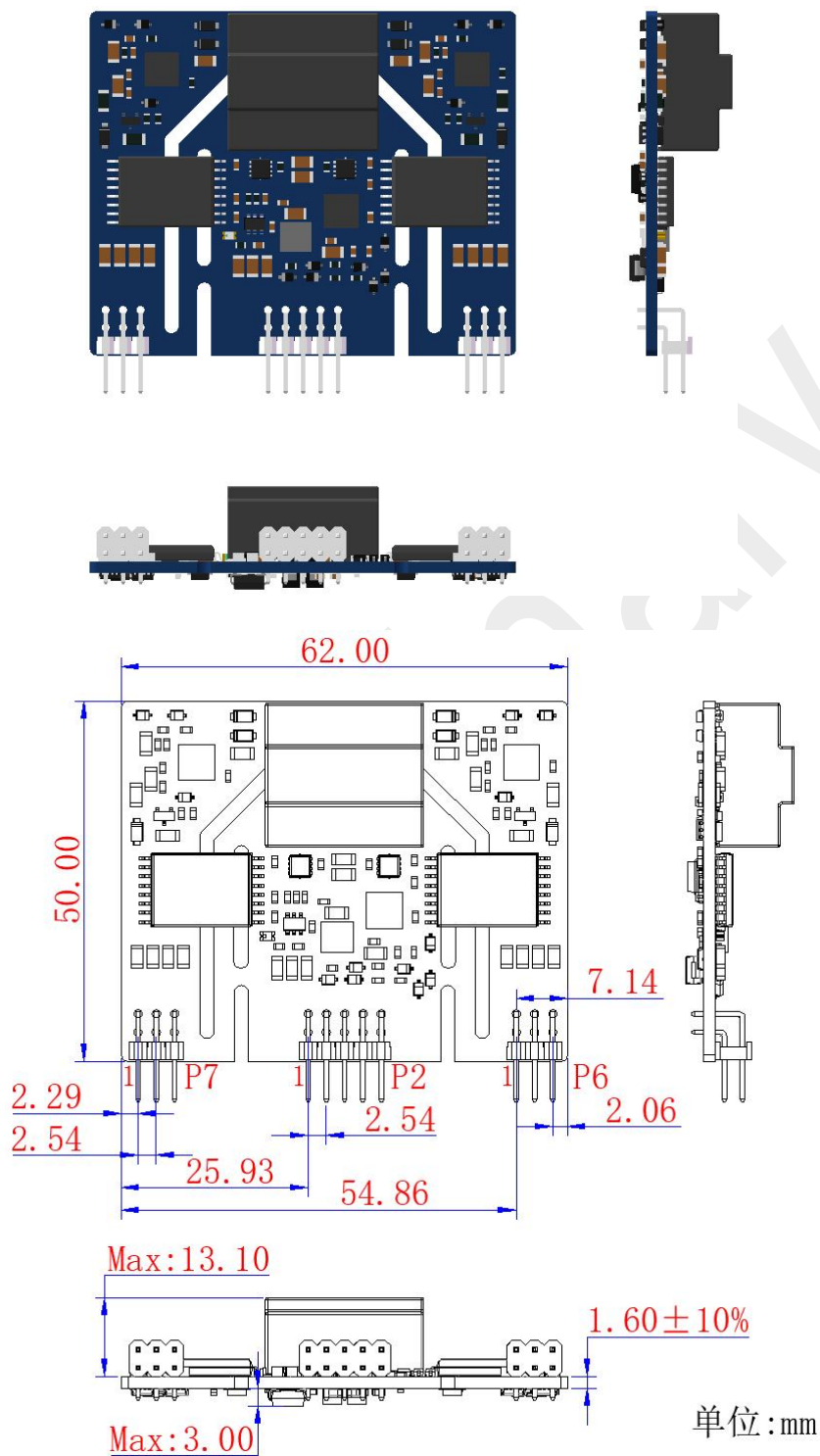

Note: 1. The thickness tolerance of the board is  $\pm 10\%$ ;

2. Other dimensional tolerances refer to GB/T1804-m.

## Update information

Date	Update the content	Version
2026.04.20	Sample specification	V0.1
2026.05.19	Add mechanical dimensions and the relationship between input signal and terminals; PDEV data	V0.2

## Ordering information

2FHC0240 can support packaging modules of different models from multiple manufacturers. When purchasing, please add the module model after the driver model, so that we can provide the driver that best meets your needs.

Driver model	Gate Voltage (V)	Operating mode	Coating
2FHC0240C20A1	18/-4	Direct mode	No
2FHC0240C20A1C	18/-4	Direct mode	Yes

## Technical support

Firstack's professional team will provide you with business consultation, technical support, product selection, price and delivery cycle and other relevant information, and guarantee to answer your questions within 48 hours.

## Legal disclaimer

This manual describes the product in detail, but does not promise to provide specific parameters for product delivery, performance or applicability. No warranty or guarantee, express or implied, is provided herein.

Firstack reserves the right to modify technical data and product specifications at any time without prior notice. Firstack's general terms and conditions of delivery apply.

**Contact information**

Tel: + 86-571 8817 2737

Website: [www.firstack.com](http://www.firstack.com)

E-mail: [fsales@firstack.com](mailto:fsales@firstack.com)

Address: 4-5F, Building 5, Xizi Wisdom Industrial Park, No.1279, Tongxie Road, Hangzhou, China

Preliminary