

A1XHPA1V-S0001 Data Sheet

Abstract

The A1XHPA1V-S0001 is a high-performance, dual-channel SiC module adaptor board (MAB) developed based on Firstack intelligent chip technology, supports SiC modules up to 3300V, and should be used with the 2FHC06M33XX. The overall architecture consists of a main control core (MCC) and multiple MAB units, the MCC and MAB are connected by a set of cables, which can flexibly match 1~4 SiC modules. The A1LPA1V-S0002 integrates driver protection, intelligent fault management, distributed NTC sampling and other functions, and is suitable for multi-parallel connection of packages such as Hitachi Linpak, and is mainly used in PV, wind, rail and other high reliability fields.

Highlights:

- Support up to 4 in parallel
- Support SiC modules up to 3300V
- Digital control
- Short-circuit protection (soft shut down)
- Miller clamping
- Intelligent fault management
- UVLO
- Distributed NTC sampling

Applications:

- PV
- Wind
- Rail

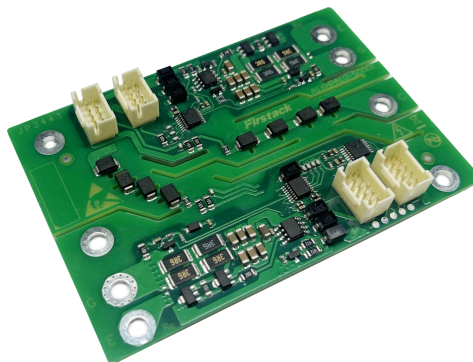

Fig.1 A1XHPA1V-S0001

Functional Block Diagram

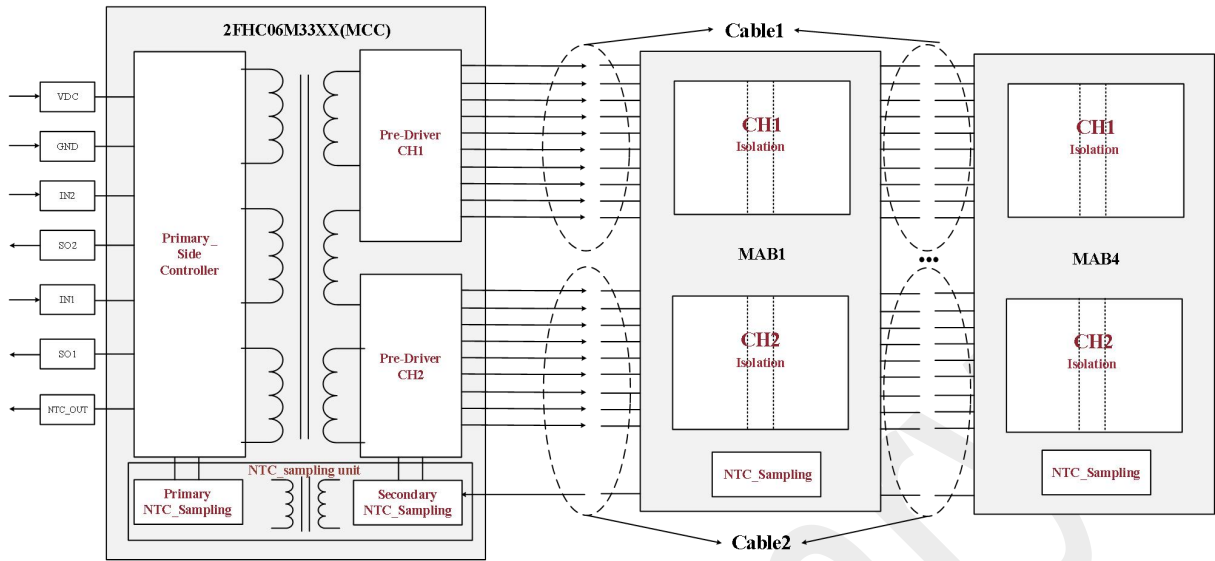

Fig.2 Functional block diagram

Connector Interface Designation

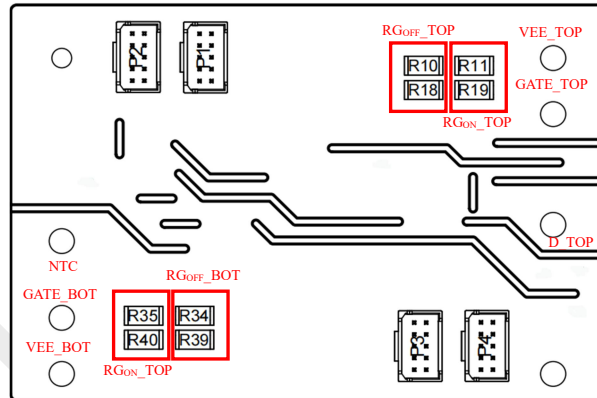
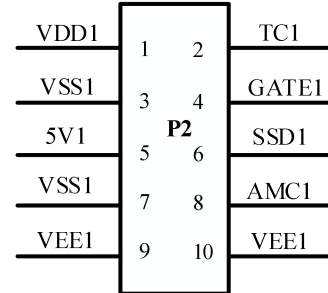
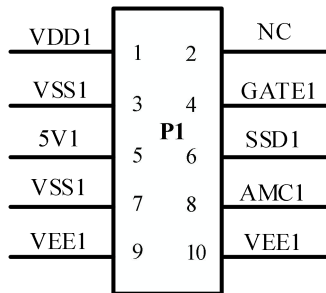

Fig.3 Connector interface designation

P1, P2 terminal pin designation

P1	Definition	Function	P2	Definition	Function
1	VDD1	Secondary side positive supply channel1	1	VDD1	Secondary side positive supply channel1
2	NC	Free	2	TC1	Short-circuit detection signal channel1
3	VSS1	Secondary side negative supply channel1	3	VSS1	Secondary side negative supply channel1
4	GATE1	Gate signal channel1	4	GATE1	Gate signal channel1
5	5V1	Secondary side 5V supply channel1	5	5V1	Secondary side 5V supply channel1
6	SSD1	Soft shut down signal channel1	6	SSD1	Soft shut down signal channel1
7	VSS1	Secondary side negative supply channel1	7	VSS1	Secondary side negative supply channel1
8	AMC1	Active miller clamping signal channel1	8	AMC1	Active miller clamping signal channel1
9	VEE1	Secondary side ground channel1	9	VEE1	Secondary side ground channel1
10	VEE1	Secondary side ground channel1	10	VEE1	Secondary side ground channel1

P3, P4 terminal pin designation

VDD2	1	2	NC
VSS2	3	4	GATE2
5V2	5	6	SSD2
5V_NTC	7	8	AMC2
NTC_IN	9	10	VEE2

VDD2	1	2	TC2
VSS2	3	4	GATE2
5V2	5	6	SSD2
5V_NTC	7	8	AMC2
NTC_OUT	9	10	VEE2

Pin	Definition	Function	Pin	Definition	Function
1	VDD2	Secondary side positive supply channel2	1	VDD2	Secondary side positive supply channel2
2	NC	Free	2	TC2	Short-circuit detection signal channel2
3	VSS2	Secondary side negative supply channel2	3	VSS2	Secondary side negative supply channel2
4	GATE2	Gate signal channel2	4	GATE2	Gate signal channel2
5	5V2	Secondary side 5V supply channel2	5	5V2	Secondary side 5V supply channel2
6	SSD2	Soft shut down signal channel2	6	SSD2	Soft shut down signal channel2
7	5V_NTC	NTC sampling circuit power supply	7	5V_NTC	NTC sampling circuit power supply
8	AMC2	Active miller clamping signal channel2	8	AMC2	Active miller clamping signal channel2
9	NTC_IN	NTC sampling input	9	NTC_OUT	NTC sampling output
10	VEE2	Secondary side ground channel2	10	VEE2	Secondary side ground channel2

3D and Mechanical Dimensions

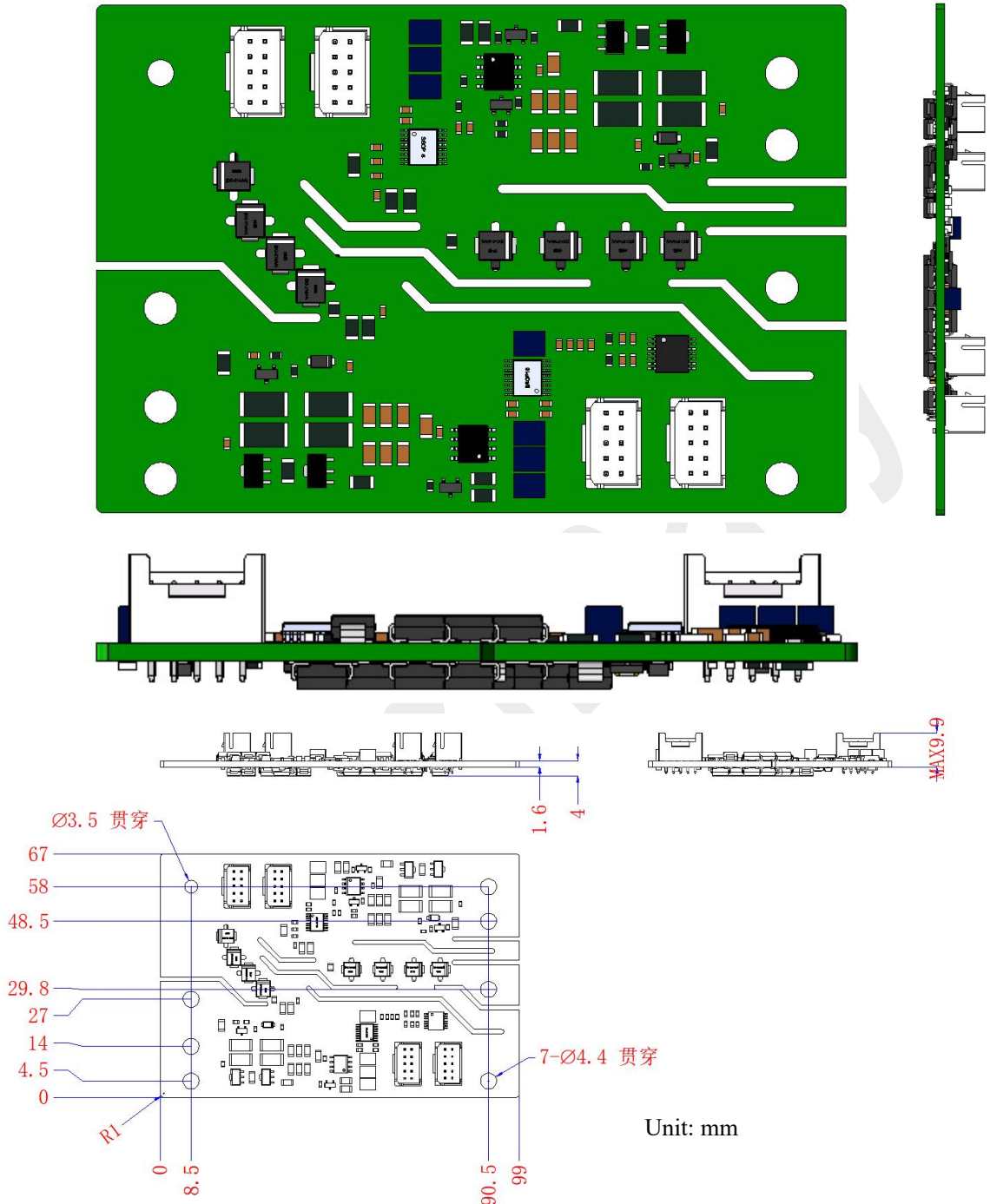

Note: 1. The thickness tolerance of the board is $\pm 10\%$;

2. Other dimensional tolerances refer to GB/T1804-m.

Technical Parameters

Absolute Maximum Ratings

Parameter	Remarks	Min	Typ	Max	Unit
Static loss per channel	Without load		0.5		W
Output power per channel	Full load		1		W
Peak current per channel		-15		20	A
Operating temperature		-40		85	°C
Storage temperature		-40		85	°C

Gate Parameters

Output voltage	Remarks	Min	Typ	Max	Unit
Total gate voltage	$V_{GSon}-V_{GSoff}$	20.5	22	24.5	V
Gate positive voltage V_{GSon}	Turn on (ON)	14.5	18	19.5	V
Gate negative voltage V_{GSoff}	Turn off (OFF)	-9.5	-4	-0.5	V

NTC Sampling

Parameter	Remarks	Duty cycle for temperature output	Unit
Temperature output	Fixed frequency 4K, variable duty cycle, output the highest temperature	Note 1	μ s

Short-Circuit Protection

Parameter	Remarks	Min	Typ	Max	Unit
V_{DS} monitoring threshold	Short-circuit protection threshold	Configurable	11	Configurable	V
Response time	Note 2	Configurable	2	Configurable	μ s
Soft shut down time		Configurable	6.24	Configurable	μ s

Miller Clamping

Parameter	Remarks	Min	Typ	Max	Unit
Time from drive signal turn-off to clamp turn-on		Configurable	1.56	Configurable	μs
Time from clamp turn-off to drive signal turn-on			500		ns
Clamp voltage			VSS (negative voltage)		

Timing Characteristics

Parameter	Remarks	Min	Typ	Max	Unit
Turn-on delay	Note 3		1.2		μs
Turn-off delay	Note 4		1.3		μs
Rise time	Note 5		15		ns
Fall time	Note 6		15		ns

Electrical Isolation

Parameter	Remarks	Min	Typ	Max	Unit
Creepage distance	Secondary to secondary side, Note 7		22		mm
Clearance distance	Secondary to secondary side		8.2		mm

1. Temperature output duty cycle (refer to Infineon NTC):

Temperature (°C)	Rntc (kΩ)	Duty Cycle (%)
-40	99.092	6.0%
-35	75.144	8.0%
-30	57.533	10.0%
-25	44.448	12.0%
-20	34.610	14.0%

-15	27.156	16.0%
-10	21.483	18.0%
-5	17.120	20.0%
0	13.727	22.0%
5	11.082	24.0%
10	9.003	26.0%
15	7.359	28.0%
20	6.049	30.0%
25	5.000	32.0%
30	4.156	34.0%
35	3.472	36.0%
40	2.914	38.0%
45	2.458	40.0%
50	2.083	42.0%
55	1.773	44.0%
60	1.515	46.0%
65	1.300	48.0%
70	1.120	50.0%
75	0.968	52.0%
80	0.840	54.0%
85	0.732	56.0%
90	0.640	58.0%
95	0.561	60.0%
100	0.493	62.0%
105	0.435	64.0%

110	0.385	66.0%
115	0.342	68.0%
120	0.304	70.0%
125	0.271	72.0%
130	0.243	74.0%
135	0.217	76.0%
140	0.195	78.0%
145	0.176	80.0%
150	0.158	82.0%

2. Response time: the time from the occurrence of the fault to the start of soft shut down;
3. Turn-on delay: the time required to transmit from the rising edge of the PWM signal from the primary input to the rising edge of the secondary of the gate driver;
4. Turn-off delay: the time required to transmit from the falling edge of the PWM signal from the primary input to the falling edge of the secondary side of the gate driver;
5. Rise time: the amount of time from 10% of the gate turn-off voltage (-4V) to 90% of the gate turn-on voltage (+18V);
6. Fall time: the amount of time from 90% of the gate turn-on voltage (+18V) to 10% of the gate turn-off voltage (-4V);
7. Creepage distance: refer to IEC61800-5-1-2007, meet the basic isolation requirements for altitudes below 2km and pollution level 2; this value takes the creepage distance of the isolation device.

Ordering Information

The A1XHPA1V-S0001 supports different part numbers of modules from multiple manufacturers. If you have a purchase request, please add the module part number after the gate driver part number, and we can provide the gate driver that best meets your requirements.

Technical Support

Firstack's professional team will provide you with business consultation and technical support. Please contact the Firstack technical sales team if you require the application manual for further information of the technical application.

Legal Disclaimer

This manual gives a detailed introduction about the product, but cannot promise to provide specific parameters. No warranty or guarantee, express or implied, is given herein as to the delivery, performance or applicability of the product.

Firstack reserves the right to modify technical data and product specifications at any time without prior notice. Firstack's general payment terms and conditions apply.

Contact Information

Tel: +86-571 8817 2737

Fax: +86-571 8817 3973

Website: www.firstack.com

Email: fsales@firstack.com

Address: 4-5/F, Building/5, Xizi Wisdom Industrial Park, No.1279 Tongxie Road, Hangzhou, China