

2FHD0320V and 2FHD0320S

Application Manual

Optical interface driver solution for PrimePACK™ module, supports multi-level

The 2FHD0320V and 2FHD0320S are dual-channel gate driver with optical interface:

- 2FHD0320V: equipped with common optical interface(AVAGO HFBR-x521)
- 2FHD0320S: equipped with ST optical interface(AVAGO HFBR-x412)

The gate drivers come with ASIC digital control, which can drive IGBTs safely and reliably. The gate drivers are suitable for Infineon PrimePACK™ as well as other brands of IGBTs in the same package. The plug-and-play gate driver can be assembled and used directly without further development.

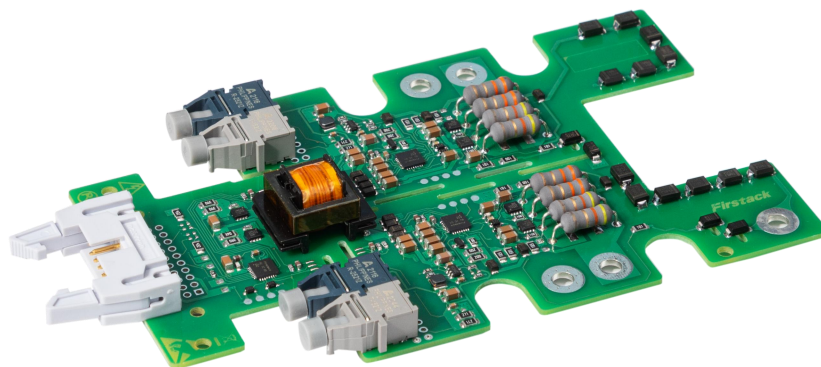

Fig.1 2FHD0320V

Contents

Driver Overview	3
Use steps and safety notice	4
Recommended Application Circuits of 2FHD0320V and 2FHD0320S	6
Description of Connector P9 interface	7
1. Overview	7
2. VCC/VDC	7
3. SO	7
Fibre-Optic Input	9
Fibre-Optic Output (Edge Feedback and Fault Code)	9
Technical Principle	11
1. Function Overview	11
2. Power Supply and Electrical Isolation	11
3. Power Monitoring	11
4. Short-Circuit Protection	12
5. Soft Shut Down	13
6. Active clamping	14
Technical Support	15
Legal Disclaimer	15
Company Information	15

Driver Overview

The 2FHD0320V and 2FHD0320S are plug-and-play gate drivers developed by Firstack based on digital control, the functional block diagram is shown in Fig. 2, and the values of the gate resistors and other key components can be found in the data sheet of the corresponding gate driver.

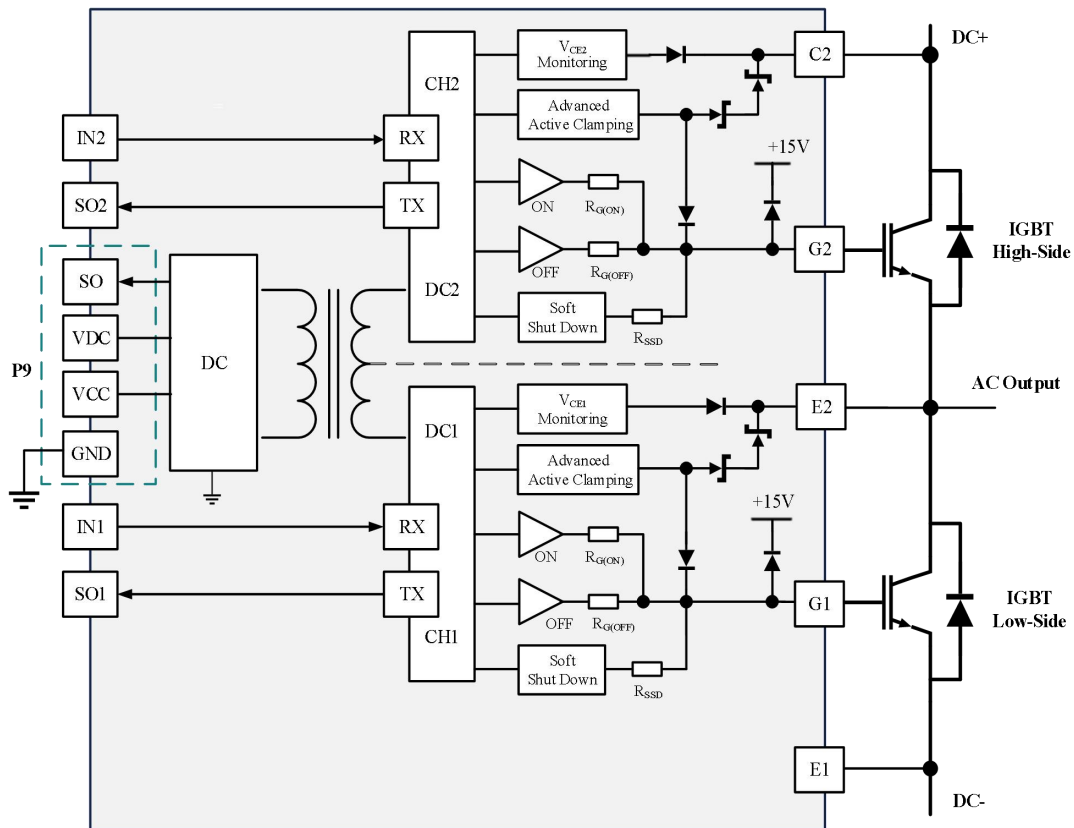

Fig.2 Functional block diagram

The gate driver has the built-in input connector P9, isolated DC/DC power supply, driving circuit, integrates Vce detection (short-circuit protection), undervoltage protection, active clamping, soft shut down and other functions, which can drive IGBT modules safely and reliably.

Use steps and safety notice

Simple use steps of the gate driver are as follows:

1. Choose suitable gate driver

When using the gate driver, pay attention to the model of the IGBT module that the gate driver is adapted to. It is invalid for non-designated IGBT modules. Improper use may cause the gate driver and the module failure.

2. Install the gate driver on the IGBT module

Any treatment of IGBT modules or gate drivers should follow the general specifications for the protection of electrostatic sensitive devices required by the international standard IEC 60747-1, Chapter IX or IEC 60340-5-2 (which means the workplace, tools, etc. must comply with these standards).

If these specifications are ignored, both the IGBT and the gate driver may be damaged.



3. Connect the gate driver to the control unit

Connect the gate driver connector to the control unit and provide a suitable power supply voltage for the gate driver.

4. Check the function of the gate driver

Check the gate voltage: for the turn-off state, the rated gate voltage is given in the corresponding data sheet, for the turn-on state, the voltage is 15V. Please also check the input current of the gate driver with and without a control signal.

These tests should be performed before installation, because the gate terminal may not be accessible after installation.

5. Set up and test the power unit

Before starting the system, it is recommended to check each IGBT module with a single pulse or

double pulse test method. Firstack specially reminds: even under the worst conditions, it is necessary to ensure that the IGBT module does not exceed the operating range specified by SOA, because the operating condition of the IGBT module strongly depends on the specific converter architecture.

Even when testing a single IGBT, power must be supplied to the remaining gate drivers in the system to ensure that the gates of all other IGBTs operate in negative voltage turn-off state. This is particularly important when testing the switching behaviour of the IGBT.

Recommended Application Circuits of 2FHD0320V and 2FHD0320S

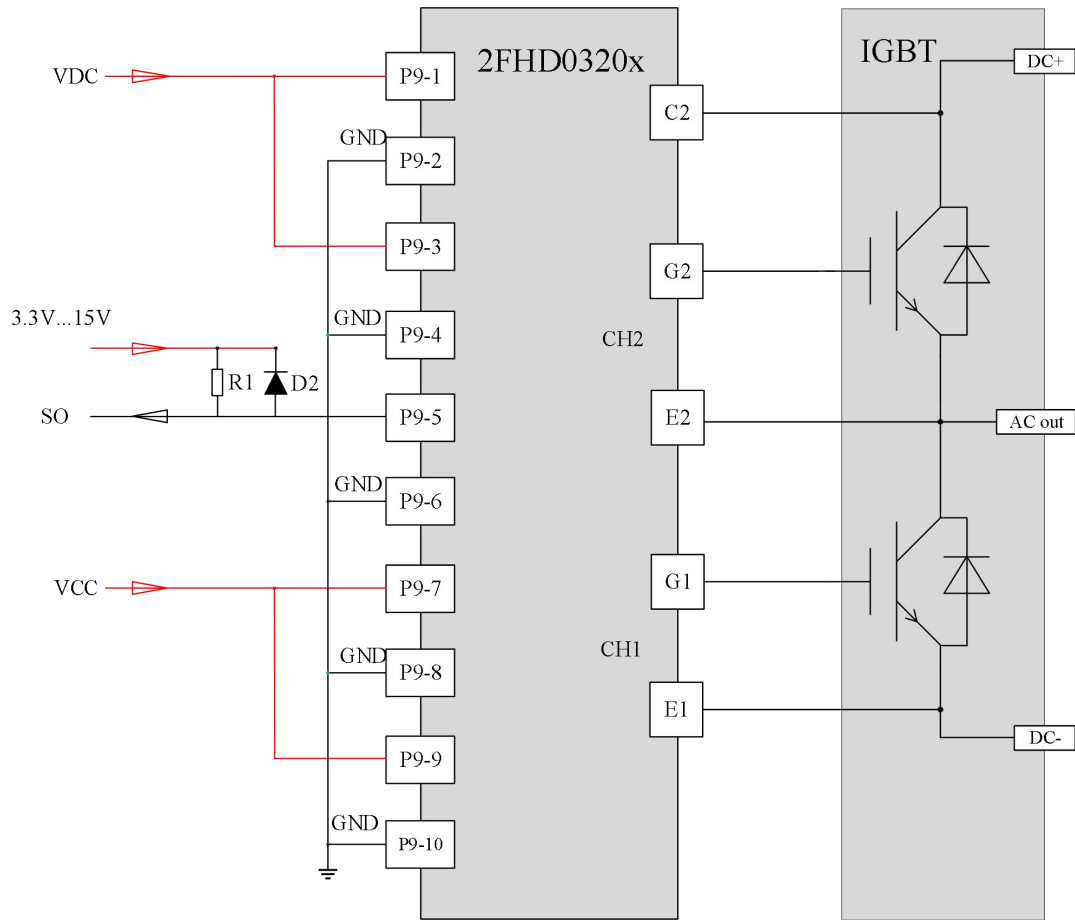

J1 Connector Pin Designation

Pin	Definition	Function	Pin	Definition	Function
1	VDC	For DC/DC power supply +15V	6	GND	Primary side ground
2	GND	Primary side ground	7	VCC	For primary side power supply +15V
3	VDC	For DC/DC power supply +15V	8	GND	Primary side ground
4	GND	Primary side ground	9	VCC	For primary side power supply +15V
5	SO	Primary side fault(high normal, low fault)	10	GND	Primary side ground

Description of Connector P9 interface

1. Overview

The P9 interface circuit of the 2FHD0320V and 2FHD0320S gate drivers is simple and easy to use.

The P9 connector of the gate drivers is equipped with the following pins:

- 4× power inputs(only need a 15V power supply)
- 1× fault signal output
- 5× GND(ground)

The gate drivers come with a 10-pin interface connector, all even pins are set as GND and odd pins are set as inputs or status outputs. The 10-pin twisted flat cable is recommended. Each input and output signal line are twisted with the corresponding GND line. All GND pins are connected together on both the 2FHD0320V and 2FHD0320S, and should be connected to the control board side. This configuration reduces parasitic inductance while increasing immunity.

2. VCC/VDC

The gate driver has two VCC and two VDC power supply terminals on the P9 connector for the primary side circuit and isolated DC/DC supply. All VCC and VDC terminals must be connected to a single 15V supply for power. the VDC and VCC terminals are split into separate pins for testing purposes only.

The total power of the gate driver is 6W, and based on 80% efficiency, 15V requires an input current of 500mA to limit the start-up impulse current.

3. SO

The output terminal SO is in the form of an open-drain transistor, which is the primary side fault signal. Under the fault state, the current value flowing through SO cannot exceed the maximum value specified in the data sheet.

When no fault is detected, SO output is in high resistance state, it is necessary to connect a pull-up resistor at the other terminal of the cable, and the pull-up voltage is recommended to be 5~15V.

When a fault is detected, the status output SO terminal is pulled to low level(connected to GND).

If not used, the SO output can be left open.

SO output logic

When an undervoltage fault occurs in primary side of the gate driver, the SO goes to high level for 40ms after reporting 40ms low level fault once.

If the undervoltage disappears before the end of the above process, SO will keep high level. If the undervoltage still exists at the end of the above process, the fault will be pulled down again until the fault disappears, then return to high level after a blocking time (80ms).

Fibre-Optic Input

These are the driving signal input terminals and it should be noted that the 2FHD0320V and 2FHD0320S do not have half-bridge mode.

Fibre-Optic Output (Edge Feedback and Fault Code)

During normal operation (the gate driver is supplied with the rated voltage without any faults), status feedback is indicated by the fibre-optic interface "light on". Faults are indicated by the "light off".

Each trip edge of the control signal is acknowledged by a short pulse of feedback from the gate driver (approx. 650 ns for light off). This can be observed by the main controller, so this method allows easy and continuous monitoring of all gate drivers and fibre-optics in the system. **Fig.3** shows the gate driver control and response signals under normal operating conditions.

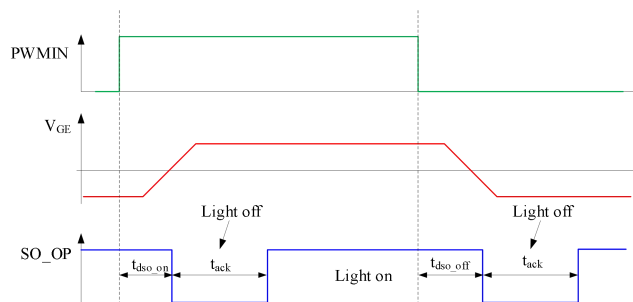

Fig.3 Gate driver behaviour and edge feedback in normal operation

Fig.4 shows the gate driver response in the event of a fault. Once a fault occurs, the gate first performs the soft shut down, then puts in negative voltage to keep the turn-off state and maintains the blocking waveform. During the fault indication time (t_{fo_fault} , about 200 μ s), the fibre-optic interface "lights off" and then it sends a fault frame, which remains sent for the blocking time (80 ms). If the fault on this side disappears before the end of the above process, the fibre-optic interface returns to "light on" after 1 blocking time (80ms) of the fault. If the fault still exists at the end of the above process, the fibre-optic interface "lights off" again and sends out fault frames until the fault has disappeared and "lights on" again within 1 blocking time (80ms).

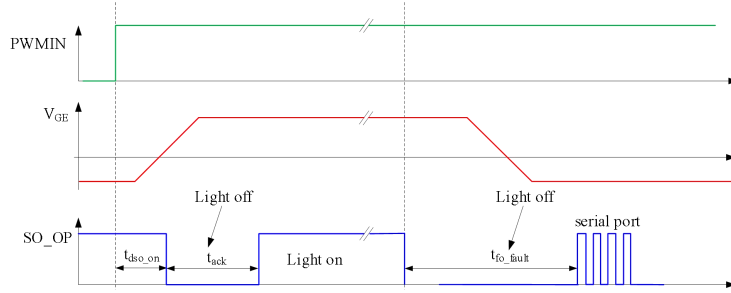

Fig.4 Gate driver behaviour and edge feedback under fault state

The fault frame communication timing is shown in **Fig.5**, which contains a start bit (default value "0"), 8 data bits and a stop bit (default value "1"). Each bit of the fault frame is about 52 μ s, and among the 8 data bits, "1" represents no fault, and "0" represents the occurrence of the fault corresponding to the bit.

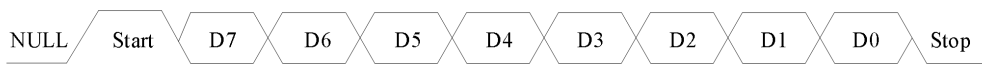

Fig.5 Fault frame communication sequence

The fault frame data bits correspond to the fault types shown in the table below:

Bit	Fault content	Corresponding fault type	Note
D0	VCE	IGBT short-circuit fault	1: No fault; 0: short-circuit fault.
D1	VP_UVP	Positive voltage undervoltage fault	1: No fault; 0: Positive voltage undervoltage fault.
D2	VN_UVP	Negative voltage undervoltage fault	1: No fault; 0: Positive voltage undervoltage fault.

(D3-D7 are not available, if you have any questions, please consult Firststack technical support)

NOTE: During power-up, the status feedback will also indicate a fault condition until the power undervoltage disappears.

Technical Principle

1. Function Overview

The 2FHD0320V and 2FHD0320S plug-and-play gate drivers are developed for IGBT modules in PrimePACK™ or the same package.

Basic functions: signal isolation, DC/DC power isolation.

Protection functions: short-circuit protection, undervoltage protection, soft shut down, active clamping, fault blocking, edge feedback, fault code.

Digital function: intelligent fault management.

The gate drivers support multi-level applications.

2. Power Supply and Electrical Isolation

This gate driver implements isolated power and signal. Power isolation is realized by the transformer, signal isolation is realized by capacitive coupling. The transformer complies with the safety isolation standard EN50178 and the primary and secondary sides fulfil protection class 2.

Please note that a stable supply voltage and current are required to power the driver.

3. Power Monitoring

The primary side, as well as the two secondary side power supplies of the gate driver have local power detection circuits, and corresponding undervoltage protection.

When undervoltage occurs in the primary side power supply, both IGBTs are driven by the negative gate voltage to maintain the turn-off state (both channels are blocked), SO feeds back the fault status signal to the master computer, and both secondary side fault fibre-optics feed the fault status signals back to the master computer.

When the positive or negative voltage on the secondary side is lower than the threshold voltage, the driver circuit will determine that an undervoltage fault has occurred, the driver circuit will automatically block the IGBT, and at the same time, the corresponding secondary side fault

fibre-optic will feedback a fault signal to the master computer.

The SO output terminal can automatically reset after the primary and secondary side undervoltage faults are removed and a corresponding fault returning time.

After the secondary side undervoltage fault is removed, the fibre-optic interface returns to "light on" after one blocking time (80ms) of the fault.

Firstack recommends no IGBT in the bridge arm should work in an undervoltage state.

1. Due to the presence of C_{CG} , when one IGBT in the bridge arm turns on, the high dv/dt from it can be coupled to the other IGBT through the C_{CG} , resulting in micro-conductance of the other IGBT.
2. Undervoltage on the primary and secondary side results in a lower gate voltage, which in turn causes an increase in IGBT switching losses.

4. Short-Circuit Protection

The driving circuit judges whether the IGBT is in a short-circuit state by detecting the collector voltage V_{CE} when the IGBT is turned on.

The collector voltage is detected by high-voltage diode. When the V_{CE} voltage exceeds the set threshold, the gate driver determines that the IGBT is in a short-circuit state, starts the soft shut down to slowly turn the IGBT off, and returns the fault to the master computer at the same time.

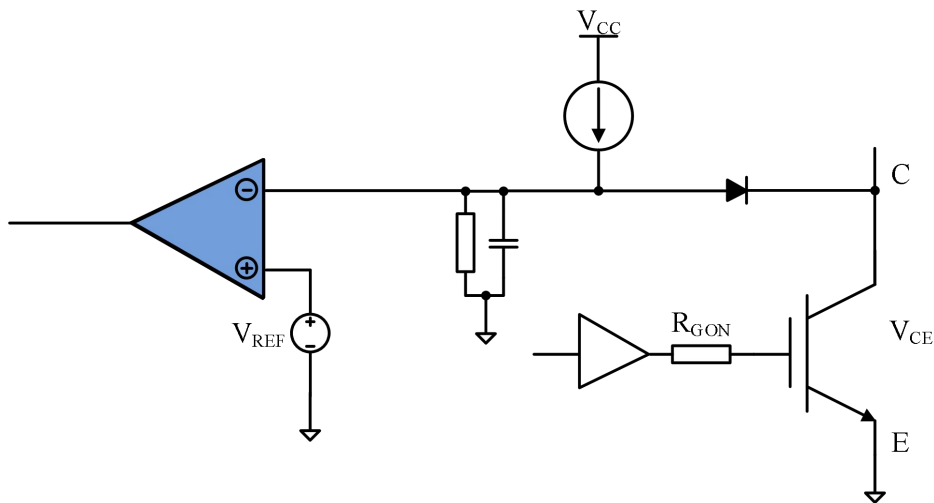
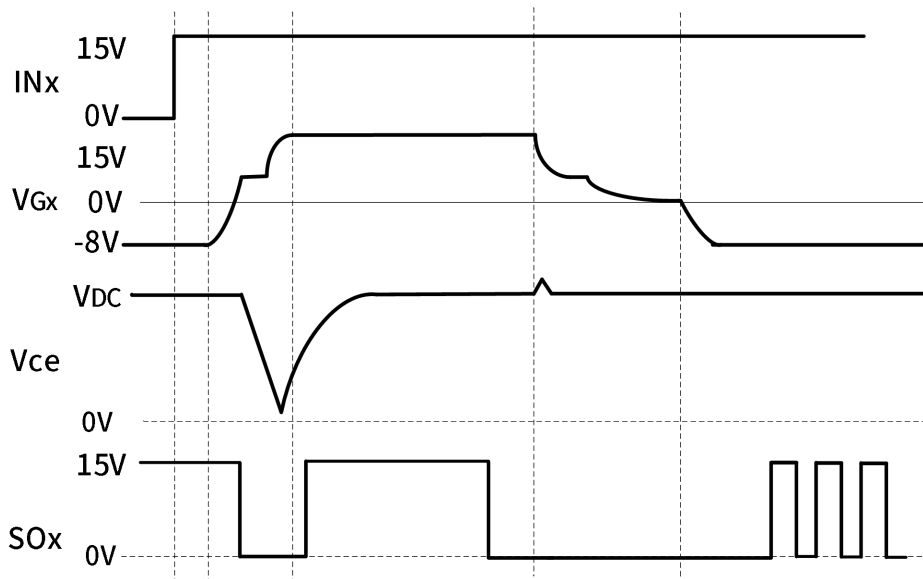

Fig.6 V_{CE} desaturation detection circuit

V_{CE} is detected again after a response time under the turn-on state (refer to Fig. 7) to determine the short-circuit condition. If this voltage is higher than the preset threshold V_{th} , the gate driver determines that the IGBT has a short-circuit and sends a fault signal to the corresponding fault fibre-optic. At the same time, soft shut down is performed to turn off the IGBT slowly, the IGBT remains in the turn-off state (cut-off), and the fault fibre-optic outputs the fault status, and the fault blocking time lasts for 80ms.

Note: The desaturation detection function is only used for short-circuit protection and cannot provide over-current protection.



5. Soft Shut Down

When IGBT desaturation occurs, V_{CE} reaches the bus voltage. At the same time, the IC will reach 4 times of the rated current or even more and the di/dt at the turn-off time will form a very high voltage spike on the parasitic inductance, which will easily damage the IGBT.

When IGBT desaturation is triggered, the digital core will detect and trigger soft shut down to turn off the IGBT, the IGBT is gradually turned down by slowly lowering the gate voltage V_{ge} , which effectively reduces the di/dt , and then reduces the voltage spike at the turn-off moment. Thus, the short-circuit protection of IGBT is achieved.

6. Active clamping

Active clamping partially turns the IGBT on when the voltage between the collector and emitter exceeds a preset threshold, thereby suppressing the collector-emitter voltage of the IGBT, which is operating in the linear region.

The 2FHD0320V and 2FHD0320S feature the function of the basic active clamping and an advanced active clamping consisting of 6 TVS, can effectively suppress turn-off overvoltage spike.

Technical Support

Firstack's professional team will provide you with business consultation, technical support, product selection, price, lead time and other related information, and guarantee to answer your questions within 48 hours.

Legal Disclaimer

This manual gives a detailed introduction about the product, but cannot promise to provide specific parameters. No warranty or guarantee, express or implied, is given herein as to the delivery, performance or applicability of the product.

Firstack reserves the right to modify technical data and product specifications at any time without prior notice. Firstack's general payment terms and conditions apply.

Company Information

Tel: +86-571 8817 2737

Fax: +86-571 8817 3973

Website: www.firstack.com

Email: fsales@firstack.com

Address: 4-5/F, Building/5, Xizi Wisdom Industrial Park, No.1279 Tongxie Road, Hangzhou, China