

## 2FSC0110T12A1 Data Sheet

### Abstract

The 2FSC0110T12A1 is a IGBT driver core without protection developed for small and medium power inverters, which can be applied to various topologies such as 2-level, T-type 3-level, NPC I-type 3-level, etc.

The 2FSC0110T12A1 has a powerful driving capability of 1W/channel ( $T_a=85^{\circ}\text{C}$ ).

The 2FSC0110T12A1 is a dual-channel driver core. The peripheral application circuit is simple, which means customers can drive the IGBT safely and reliably without investing in debugging the driver core.

### Highlights:

- 1W/10A
- Support up to 1200V module
- Support multi-level applications

### Applications:

- PV
- ESS

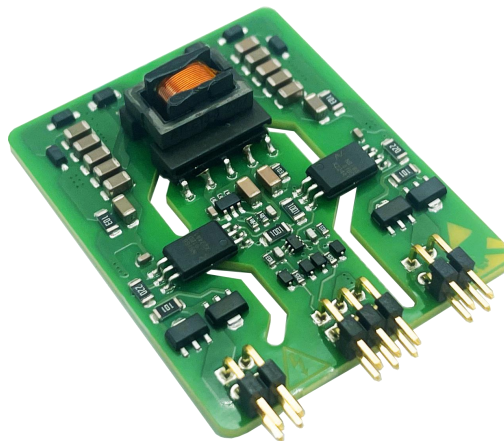

**Fig.1** 2FSC0110T12A1

**Functional Block Diagram**

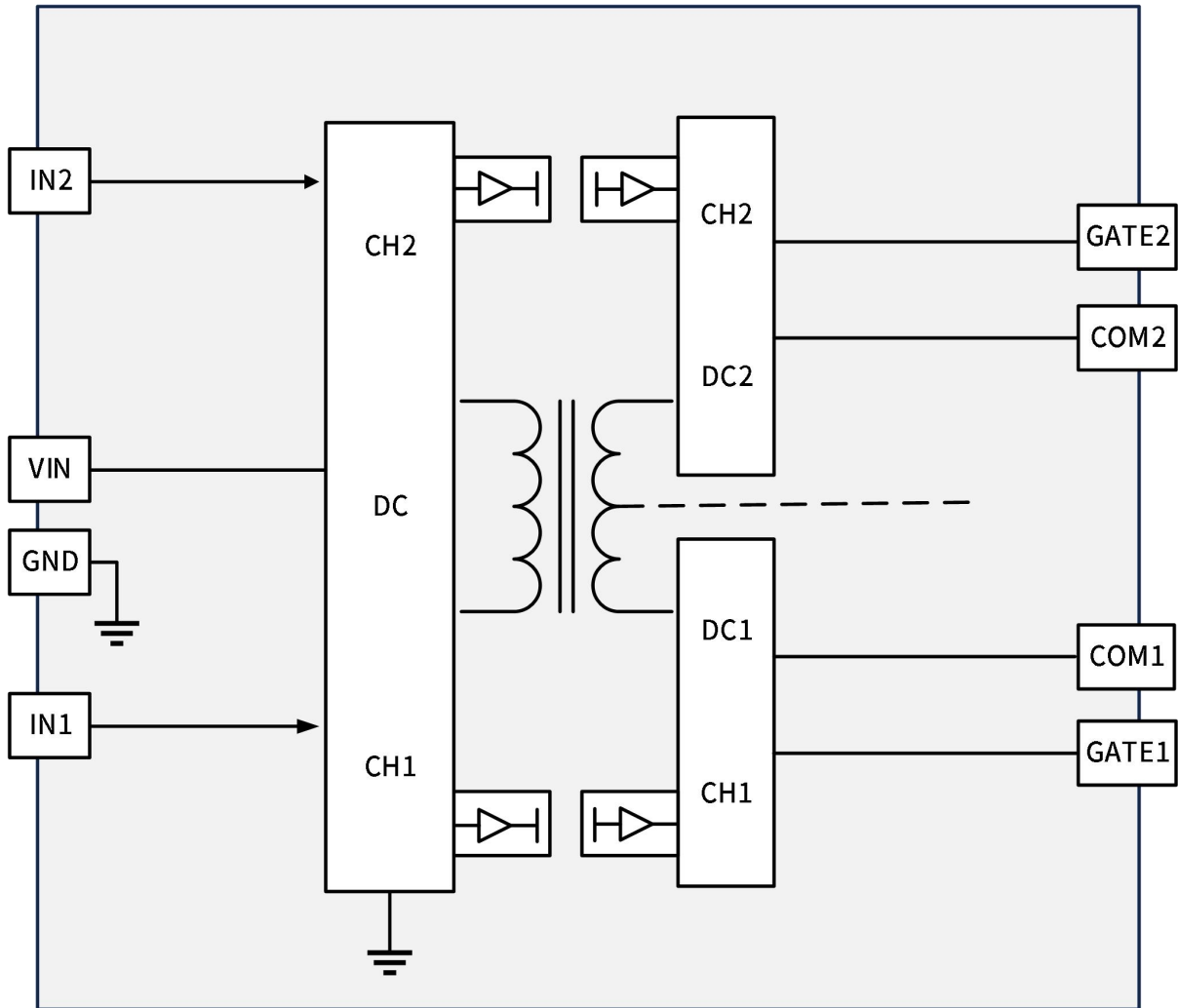

**Fig.2** Functional block diagram

## Use Steps and Safety Notice

Simple use steps of the gate driver are as follows:

### 1. Choose suitable gate driver

When using the gate driver, pay attention to the model of the IGBT module that the gate driver is adapted to. It is invalid for non-designated IGBT modules. Improper use may cause the drive and the module failure.

### 2. Install the gate driver on the IGBT module

Any treatment of IGBT modules or gate drivers should follow the general specifications for the protection of electrostatic sensitive devices required by the international standard IEC 60747-1, Chapter IX or IEC60340-5-2 (which means the workplace, tools, etc. must comply with these standards).

If these specifications are ignored, both the IGBT  
and the gate driver may be damaged.



### 3. Connect the gate driver to the control unit

Connect the gate driver connector (fiber optic) to the control unit and provide a suitable power supply voltage for the gate driver.

### 4. Check the function of the gate driver

Check the gate voltage: for the turn-off state, the rated gate voltage is given in the corresponding data sheet; for the turn-on state, the voltage is 15V. Please also check the input current of the gate driver with and without a control signal. For Firstack's digital gate driver, the gate driver status indicator TEST (green) is always on after the gate driver is provided a suitable supply voltage.

These tests should be performed before installation, because the gate terminal may not be accessible after installation.

### 5. Set up and test the power unit

Before starting the system, it is recommended to check each IGBT module with single pulse and double pulse test method separately. In particular, Firstack recommends that users ensure that the IGBT module does not exceed the operating range specified by SOA even under the worst conditions, as this is strongly dependent on the specific converter architecture.

### 3D and Mechanical Dimensions

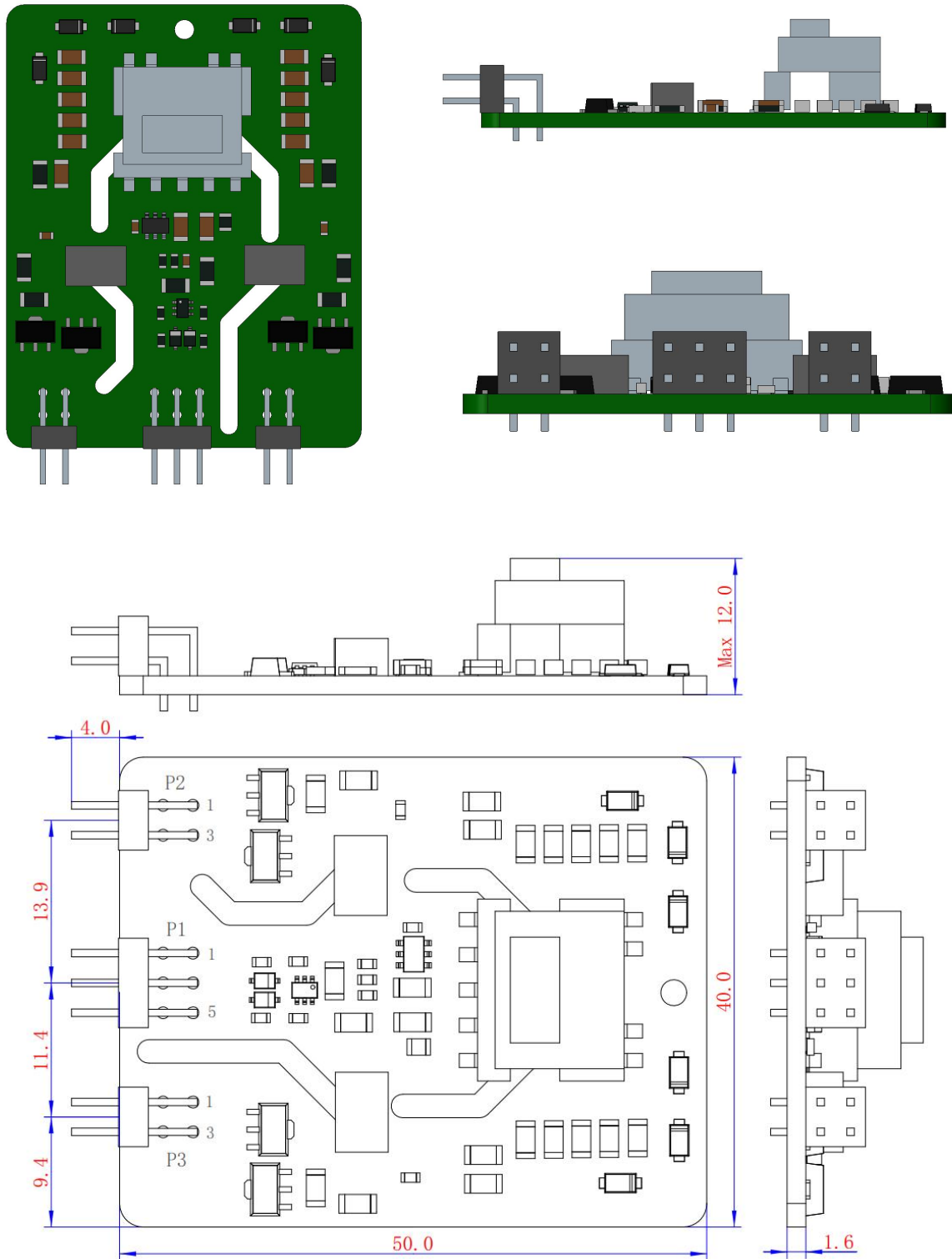

**Fig.3** 3D and mechanical dimensions (unit: mm)

- Note: 1. The thickness of the board tolerance is  $\pm 10\%$ ;  
 2. Other dimensional tolerances refer to GB/T1804-m.

## Pin Designation

Input signal P1 pin designation:

Pin	Definition	Function	Pin	Definition	Function
1	IN1	Top IGBT PWM signal On=5V/Off=0V	2	IN2	Bottom IGBT PWM signal On=5V/Off=0V
3	GND	Primary side ground	4	GND	Primary side ground
5	V <sub>DC</sub>	Supply voltage	6	NC	Free

OUTER P2 pin designation:

Pin	Definition	Function	Pin	Definition	Function
1	GATE2	Secondary side IGBT 2 gate signal	2	GATE2	Secondary side IGBT 2 gate signal
3	COM2	Secondary side IGBT 2 ground	4	COM2	Secondary side IGBT 2 ground

OUTER P3 pin designation:

Pin	Definition	Function	Pin	Definition	Function
1	COM1	Secondary side IGBT 1 ground	2	COM1	Secondary side IGBT 1 ground
3	GATE1	Secondary side IGBT 1 gate signal	4	GATE1	Secondary side IGBT 1 gate signal

---

## Technical Parameters

---

### Absolute Maximum Ratings

---

Parameter	Remarks	Min	Max	Unit
$V_{DC}$	$V_{DC}$ to GND	0	12.5	V
Logic input and output voltages	Primary side, to GND	0	15	V
Gate peak current		-10	10	A
Output power per channel	$T_A \leq 85^\circ\text{C}$		1	W
	$T_A \leq 105^\circ\text{C}$		0.5	W
Test voltage (50Hz/1min)	Primary to secondary side	5000		$V_{RMS}$
	Secondary to secondary side	4000		$V_{RMS}$
Operating temperature		-40	+105	$^\circ\text{C}$
Storage temperature		-40	+105	$^\circ\text{C}$

---

### Recommended Operating Conditions

---

Parameter	Remarks	Min	Typ	Max	Unit
$V_{DC}$		11.5	12	12.5	V
$IN_x$	High level	4.5	5	5.5	V

---

## Electrical Characteristics

Power Supply	Remarks	Min	Typ	Max	Unit
Supply current	Without load, Note 1		0.05		A
Coupling capacitance	Primary to secondary side, Note 2		9		pF

## Logic Inputs & Outputs

Input Impedance			15		kΩ
Turn-on threshold	5V PWM input, Note 3		2.5		V
Turn-off threshold	5V PWM input, Note 4		2.5		V

## Timing Characteristics

Turn-on delay	TOP, Note 6		220		ns
	BOT, Note 6		220		ns
Turn-off delay	TOP, Note 7		400		ns
	BOT, Note 7		400		ns
Rise time	TOP, Note 8		20		ns
	BOT, Note 8		20		ns
Fall time	TOP, Note 9		20		ns
	BOT, Note 9		20		ns

## Output Characteristics

Gate turn-on voltage			15		V
Gate turn-off voltage			-5		V
Gate static impedance			14		MΩ

## Electrical Isolation

Creepage distance	Primary to secondary side, Note 10	8			mm
	Secondary to secondary side	5.5			mm

---

Clearance distance	Primary to secondary side	5.5	mm
	Secondary to secondary side	5.5	mm

---

## Note:

1. Supply current: no PWM input, but connected to the IGBT module;
2. Coupling capacitance: the coupling capacitance is within the values given in the table;
3. Turn-on threshold: input voltage value at the moment of level-flip at turn-on;
4. Turn-off threshold: input voltage value at the moment of level-flip at turn-off;
5. Response time: the time from the occurrence of the fault to the start of soft shut down;
6. Turn-on delay: the time required to transmit from the rising edge of the PWM signal from the primary input to the rising edge of the secondary of the gate driver;
7. Turn-off delay: the time required to transmit from the falling edge of the PWM signal from the primary input to the falling edge of the secondary side of the gate driver;
8. Rise time: the amount of time from 10% of the gate turn-off voltage (-5V) to 90% of the gate turn-on voltage (+15V);
9. Fall time: the amount of time from 90% of the gate turn-on voltage (+15V) to 10% of the gate turn-off voltage (-5V);
10. Creepage distance: refer to IEC61800-5-1-2007, meet the basic isolation requirements for altitudes below 2km and pollution level 2.



## Derating Curve

Derating Curve Per Channel

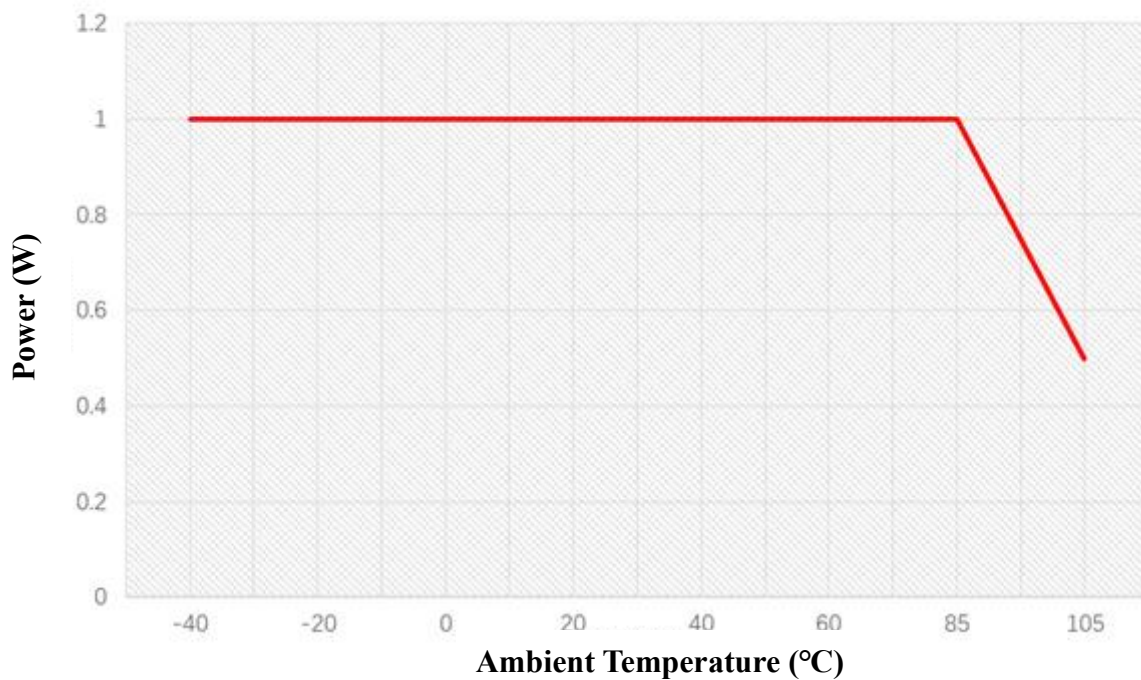
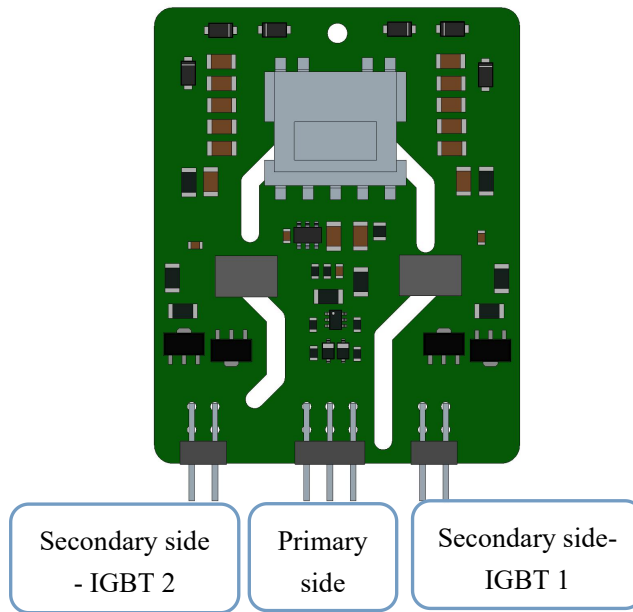
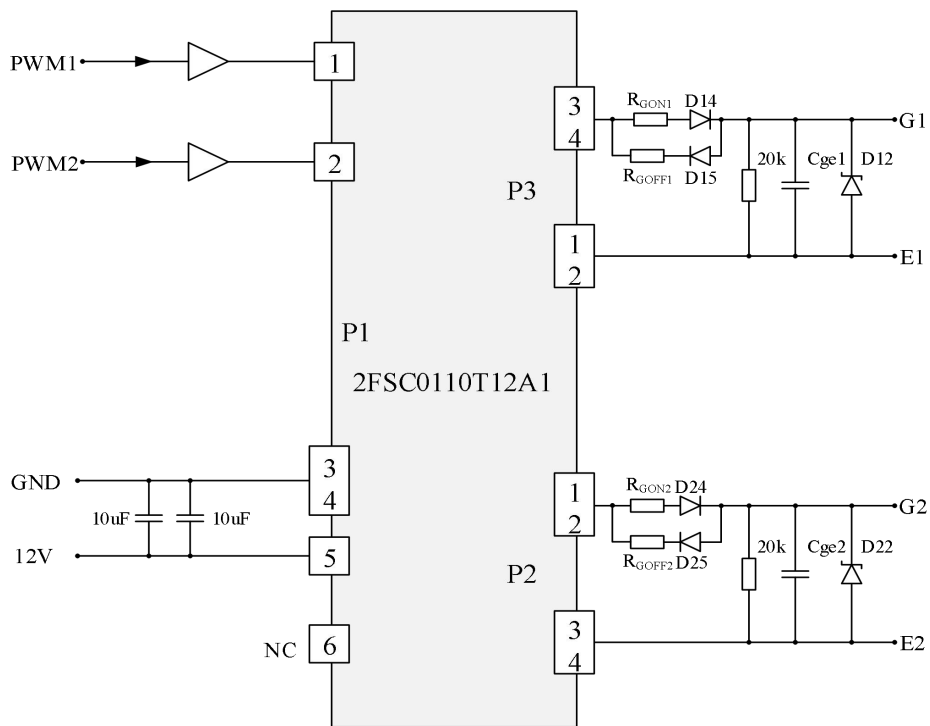

Fig.4 Derating curve

**Application Note**



**Fig.5** Primary and secondary side of the C-core-s driver board



**Fig.6** 2FSC0110T12A1 typical application

### ◆ **V<sub>DC</sub> terminal**

V<sub>DC</sub> terminal, the primary-side power supply, provide a ceramic chip capacitor of about 20μF.

### ◆ **GND terminal**

GND terminal, primary side ground.

### ◆ **IN<sub>X</sub> terminal**

IN<sub>X</sub> (1: OUTER; 2: INNER; the same meaning in the following paper) is the PWM input terminal, which can input PWM signals with 5V logic level. A high level is a valid turn-on signal.

### ◆ **GATE terminal**

The GH<sub>X</sub> and GL<sub>X</sub> terminals are connected with turn-on resistor R<sub>GONX</sub> and turn-off resistor R<sub>GOFFX</sub> to the IGBT gate respectively to control the switching speed of IGBT. It is recommended to connect about 20k resistors in parallel between G and E.

### ◆ **Gate capacitor C<sub>gex</sub>**

In order to improve the turn-on and turn-off process of the IGBT, the capacitor C<sub>gex</sub> can be added, the general C<sub>gex</sub> value is taken as 0.8 to 1.2 times of the IGBT input capacitance C<sub>ies</sub>, but it is not recommended, unless the module data sheet recommends.

### ◆ **Gate clamp diode D<sub>x2</sub>**

In order to prevent the gate voltage from being too high under extreme operating conditions such as short-circuit, it is necessary to increase the gate clamp diode D<sub>x2</sub>, it is recommended that the clamp voltage is about 16V; both TVS and Zener diode can be, bi-directional, the SMAJ16CA for TVS is recommended, the brand is Littelfuse; the G<sub>X</sub> adopts the turn-on resistor R<sub>GONX</sub> (R2//R3) and the turn-off resistor R<sub>GOFFX</sub> (R3) by connecting a diode (D1) to control the switching speed of the IGBT. The fast recovery diode FU3 is recommended for D1, the brand is GOOD-ARK. A 20k (R1) resistor is recommended to be connected in parallel between the G and E.

## Ordering Information

The 2FSC0110T12A1 is a gate driver core that can support different part numbers of IGBT modules from multiple manufacturers. If you have a purchase request, please contact us, and we can provide the gate driver that best meets your needs.

## Technical Support

Firstack's professional team will provide you with business consultation and technical support. Please contact the Firstack technical sales team if you require the application manual for further information of the technical application.

## Legal Disclaimer

The instruction manual provides a detailed description of the product but does not commit to providing specific parameters regarding the delivery, performance, or applicability of the product. This document does not offer any express or implied warranties or guarantees.

Firstack reserves the right to modify technical data and product specifications at any time without prior notice. The general delivery terms and conditions of Firstack apply.

## Contact Information

Tel: +86-571 8817 2737

Fax: +86-571 8817 3973

Website: [www.firstack.com](http://www.firstack.com)

Email: [fsales@firstack.com](mailto:fsales@firstack.com)

Address: 4-5/F, Building/5, Xizi Wisdom Industrial Park, No.1279 Tongxie Road, Hangzhou, China