

HV1027P Data Sheet

Abstract

The HV1027P series are plug-and-play drivers based on Firstack digital intelligent IGBT gate drivers, which are specially developed for IHV package. They are suitable for 4500V and 6500V IGBT modules, and have the advantages of powerful functions, high reliability and good EMC characteristics. They apply for 2-level and multi-level converters, covering various fields such as rail, traction, HVDC, smart grid and so on.

Highlights:

- Dynamically controllable gate
- Double short-circuit protection: di/dt+Vce desaturation
- GE overload protection
- Digitally dynamic advanced active clamping
- Power supply undervoltage protection

Applications:

- Grid
- Rail
- Motor drives

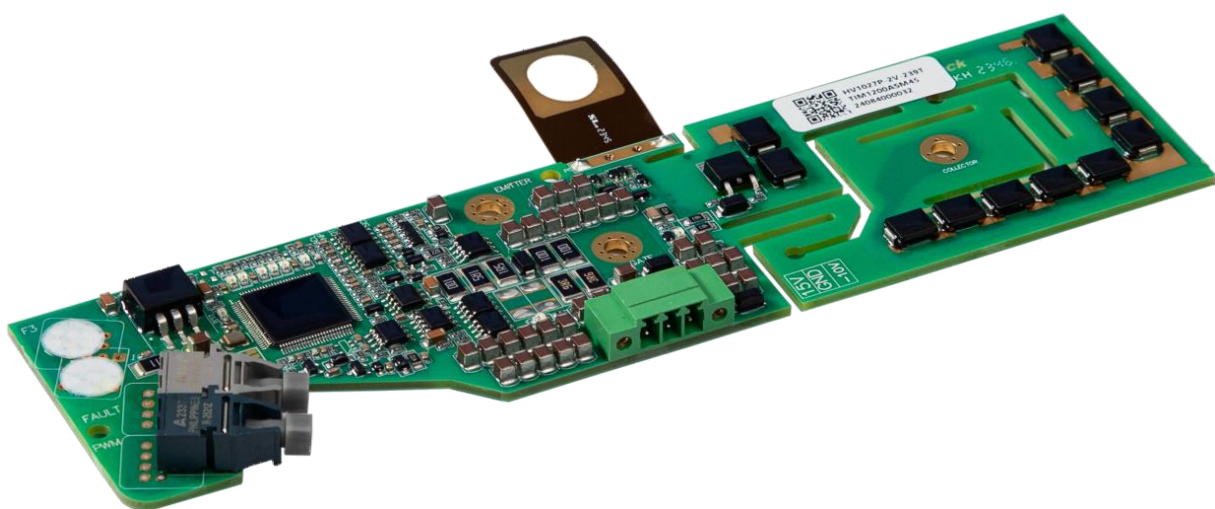

Fig.1 HV1027P

Contents

Abstract.....	1
Functional Block Diagram.....	3
Use Steps and Safety Notice.....	4
Mechanical Dimensions.....	5
Pin Designation.....	6
LED Status Indicator.....	7
Technical parameters.....	8
Function Description.....	10
◆ Short-circuit protection—di/dt.....	10
◆ Short-circuit protection— V_{CE} monitoring.....	10
◆ Undervoltage protection.....	11
◆ Soft shut down.....	11
◆ Digitally dynamic advanced active clamping D ² A ² C technology.....	12
◆ Multi-level turn-off.....	14
◆ Highly robust DC/DC.....	15
◆ Fiber optic port notification signal.....	16
Gate resistor indication.....	18
Ordering Information.....	20
Technical Support.....	20
Legal Disclaimer.....	20
Contact Information.....	20

Functional Block Diagram

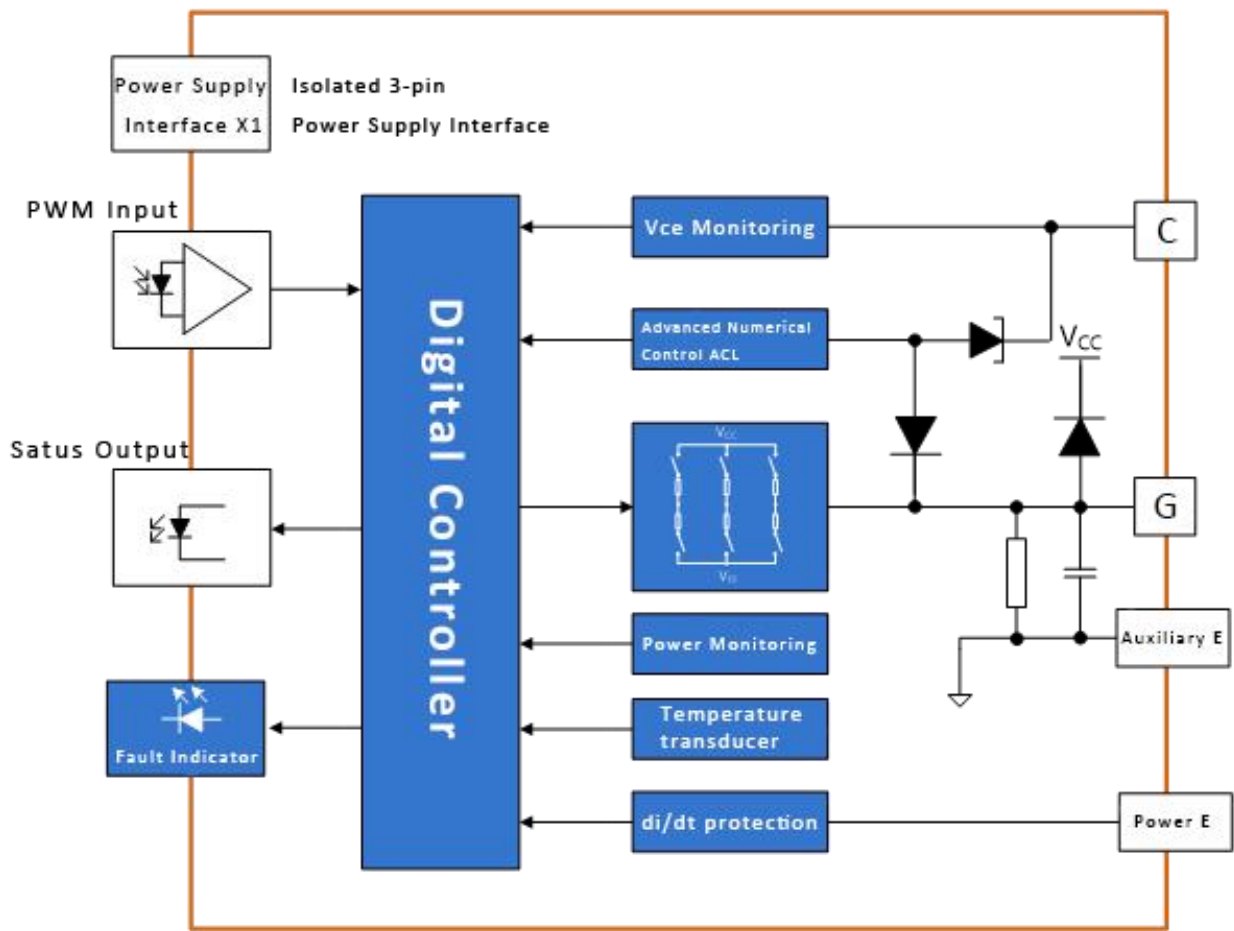

Fig.2 Functional block diagram

Use Steps and Safety Notice

Simple use steps of the gate driver are as follows:

1. Choose suitable gate driver

When using the gate driver, pay attention to the model of the IGBT module that the gate driver is adapted to. It is invalid for non-designated IGBT modules. Improper use may cause the gate driver and the module failure.

2. Install the gate driver on the IGBT module

Any treatment of IGBT modules or gate drivers should follow the general specifications for the protection of electrostatic sensitive devices required by the international standard IEC 60747-1, Chapter IX or IEC 60340-5-2 (which means the workplace, tools, etc. must comply with these standards).

If these specifications are ignored, both the IGBT
and the gate driver may be damaged.



3. Connect the gate driver to the control unit

Connect the gate driver connector (fiber optic) to the control unit and provide a suitable power supply voltage for the gate driver.

4. Check the function of the gate driver

Check the gate voltage: for the turn-off state, the rated gate voltage is given in the corresponding data sheet, for the turn-on state, the voltage is 15V. Please also check the input current of the gate driver with and without a control signal. For Firstack's digital gate driver, the gate driver status indicator TEST (yellow) remains on after the gate driver has been provided with a suitable supply voltage.

These tests should be performed before installation, because the gate terminal may not be accessible after installation.

5. Set up and test the power unit

The operating condition of the IGBT module strongly depends on the specific converter structure. Before starting the system, it is recommended to check each IGBT module with a single pulse or double pulse test method.

Firstack specially reminds: even under the worst conditions, it is necessary to ensure that the IGBT module does not exceed the operating range specified by SOA.

Mechanical Dimensions

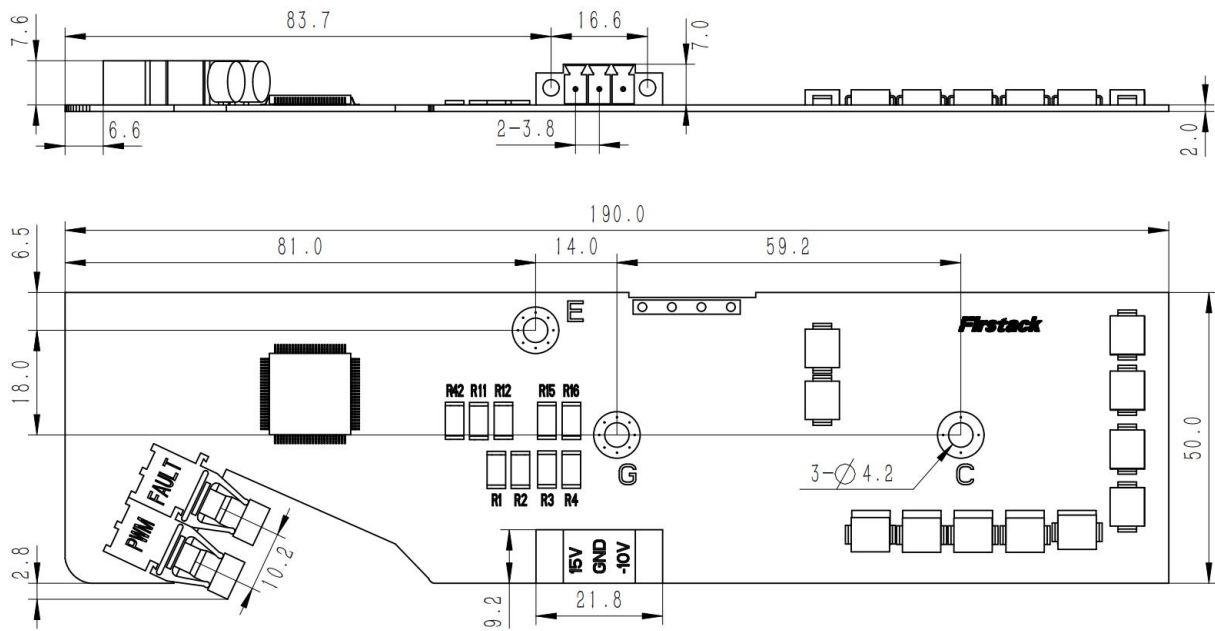

unit: mm

Fig.3 Mechanical dimensions of HV1027P

- Note: 1. The thickness tolerance of the board is $\pm 10\%$;
 2. Other dimensional tolerances refer to GB/T1804-m.

Connector Manufacturer and Part Number

Number	Ref	Manufacturer	Part number	Recommended matching terminals
1	#1	Wurth	691325310003	691364300003
2	PWM, F3	Avago	HFBR-2521Z	
3	FAULT	Avago	HFBR-1521Z	

Note: The receiving fiber and the sending fiber are of the same type according to requirements.

Pin Designation

#1 Pin:

Pin	Label	Note	Pin	Label	Note
1	V _{CC}	Primary side positive voltage input	2	GND	Primary side ground
3	V _{EE}	Primary side negative voltage input			

LED Status Indicator

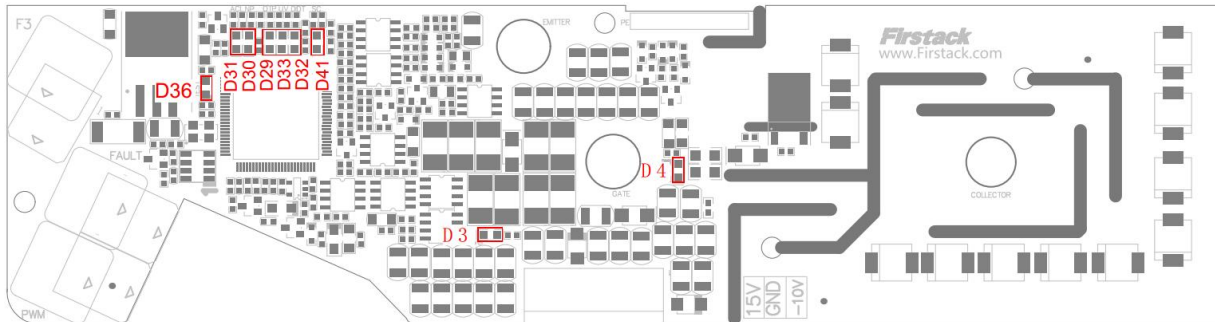

Fig.4 LED status indicator

For the convenience of customers, several LED status indication are added on the Firststack gate driver board to facilitate customers to know the operating status of the gate driver board and converter. The specific explanation is as follows:

LED Status Indicator

Number	Ref	Interface	Note
1	D31	ACL	Once the ACL is triggered, it is always on, unless restarted
2	D30	NP	Once the NP is triggered, it is always on, unless restarted
3	D29	OTP	Once triggered by overheating, it is always on, unless restarted
4	D33	UV	Once triggered by undervoltage, it is always on, unless restarted
5	D32	DIDT	Once triggered by a short-circuit, it is always on, unless restarted
6	D41	SC	Once triggered by a short-circuit, it is always on, unless restarted
7	D36	TEST	Light on when there is no fault, otherwise off
8	D3	Power	Always on when having electricity supply, otherwise off
9	D4	GE	GE signal indicator, light on when turned on, otherwise off

Technical Parameters

Absolute Maximum Ratings

Parameters	Ref	Min	Typ	Max	Unit	Remarks
Supply voltage	V_{IN}	14.5		15.5	V	To GND
Gate peak current	I_{GPEAK}	-30		27	A	
Output power			10		W	$T_A \leq 85^\circ\text{C}$
Operating temperature	T_{op}	-40		+85	$^\circ\text{C}$	
Storage temperature	T_{stg}	-40		+85	$^\circ\text{C}$	
V_{CC}		14.5		15.5	V	To GND
V_{EE}		-9		-10	V	To GND
Switching frequency				5	kHz	

Electrical Characteristics

Power	Ref	Min.	Typ.	Max.	Unit	Remarks
Supply current	I_{cc}		0.11		A	Without load, Note 1

Short-circuit Protection

V_{CE} short-circuit protection

V_{CE} threshold	V_{REF_SC}		10.2		V	
V_{CE} protection response time			8		μs	Note 2
di/dt protection response time			3		μs	
Blocking time			90		ms	

Undervoltage protection

Positive undervoltage threshold			12.7		V	
Negative undervoltage threshold			-6.5		V	

Undervoltage protection hysteresis		0.6		V	
Timing Characteristics					
Turn-on delay	t_{don}	450		ns	Note 3
Turn-off delay	t_{doff}	350		ns	Note 4
Rise time	t_r	15.5		ns	Note 5
Fall time	t_f	12.5		ns	Note 6

Unless otherwise specified, all data are based on +25°C and $V_{CC}=15V$ and $V_{EE}=-9.5V$.

Note:

1. Supply current: input current increased by connecting the HV1027P driver board when the FPS08-15K power supply has 15V input. The gate driver board does not input any PWM signal but connects the IGBT module;
2. Response time: the time from the occurrence of the fault to the start of soft shut down;
3. Turn-on delay: the time required to transmit the rising edge of the PWM signal input from the primary side to the rising edge of the secondary side of the gate driver when the IGBT is not connected;
4. Turn-off delay: the time required to transmit the falling edge of the PWM signal input from the primary side to the falling edge of the secondary side of the gate driver when the IGBT is not connected;
5. Rise time: the amount of time from 10% of the gate turn-off voltage(-9.5V) to the gate turn-on voltage(+15V);
6. Fall Time: the amount of time from 90% of the gate turn-on voltage(+15V) to the gate turn-off voltage(-10V).

Function Description

◆ Short-circuit protection—di/dt

The driving circuit has di/dt protection function. The di/dt protection is based on voltage measurement of power emitter (PE) and auxiliary emitter (AE). The voltage V_{PA} between the auxiliary emitter and the power emitter is proportional to the rate of change di/dt of the collector current I_C .

When operates normally, di/dt is usually tens of amperes per microsecond, but when IGBT has a short-circuit, di/dt will reach thousands of amperes per microsecond, with a difference of hundreds of times. Because di/dt protection directly monitors the change rate of current, it does not need a blank time like V_{CE} monitoring, so di/dt response is faster.

Compared with V_{CE} -based short-circuit protection, di/dt protection has faster response, higher signal-to-noise ratio and more obvious competitiveness in multi-level applications.

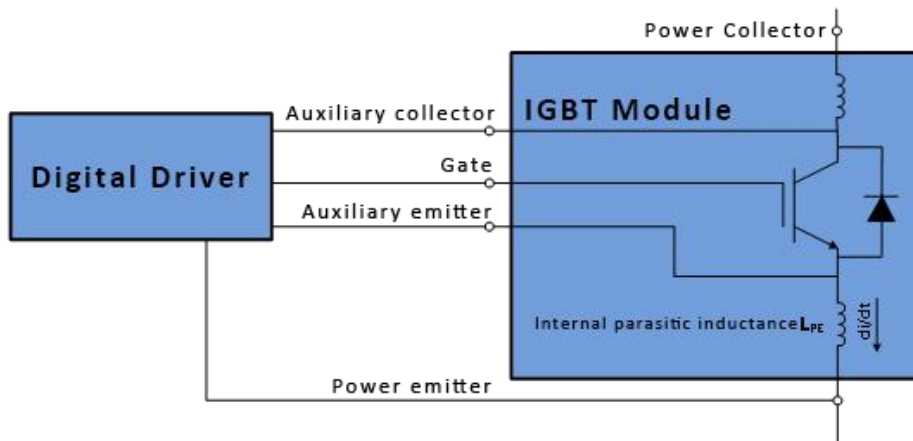

Fig.5 di/dt detection circuit

◆ Short-circuit protection— V_{CE} monitoring

The driving circuit judges whether the IGBT is in a short-circuit state by detecting the master computer voltage V_{CE} when the IGBT is turned on.

The V_{CE} voltage is detected by resistance division. When the V_{CE} voltage exceeds the set threshold, the gate driver determines that the IGBT is in a short-circuit state and returns the fault to the master computer.

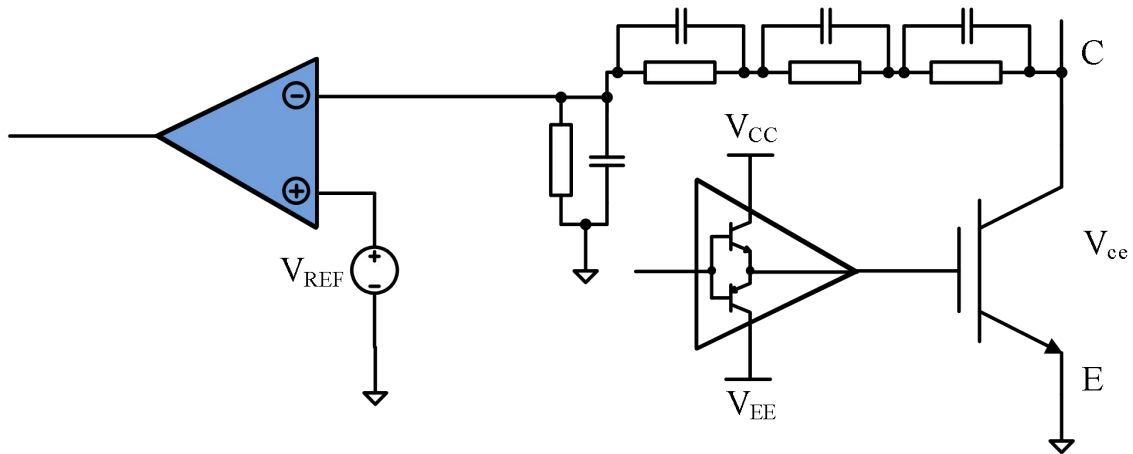

Fig.6 V_{CE} monitoring circuit

◆ **Undervoltage protection**

The gate driver board monitors the positive and negative power supply of the secondary side at the same time. When the absolute value of the positive or negative voltage of the secondary side is lower than the threshold voltage, the driving circuit determines that an undervoltage fault has occurred and will feed back a fault signal to the master computer.

For IGBT bridge arms, the Firstack intelligent gate driver strongly suggests that any IGBT should not operate undervoltage. Because of the existence of C_{GC} , when an IGBT in the bridge arm is turned on, its high dv/dt can be coupled to another IGBT through C_{GC} , which leads to a slight turn-on of IGBT. At the same time, low gate voltage will increase the switching loss of IGBT.

◆ **Soft shut down**

When a direct short-circuit occurs, IGBT will quickly desaturate, and the voltage V_{CE} at both terminals will reach the DC bus voltage; while the current I_C flowing through IGBT will reach 4 times or more of the rated current (depending on IGBT type and gate voltage). At this time, the power consumed by IGBT will instantly reach megawatt level. If the short-circuit current cannot be reduced in a short time, the IGBT will be burned down due to overheating of the chip. However, if the turn-off speed during short-circuit is as fast as normal turn-off, a large di/dt will be generated. Due to the existence of parasitic inductance, this di/dt will bring a large voltage spike at both terminals of IGBT, which will cause IGBT overvoltage breakdown.

In order to suppress the turn-off spike in short circuit, the Firstack intelligent driving circuit introduces soft shut

down technology. In case of direct short-circuit of IGBT, on the premise of ensuring that the short-circuit time under 10us, by slowly reducing the gate voltage V_{GE} , the IGBT chip will not be burned out due to overheating, and the di/dt will be effectively reduced, thus avoiding the voltage spike when the IGBT is turned off, which ensures the safety of the IGBT.

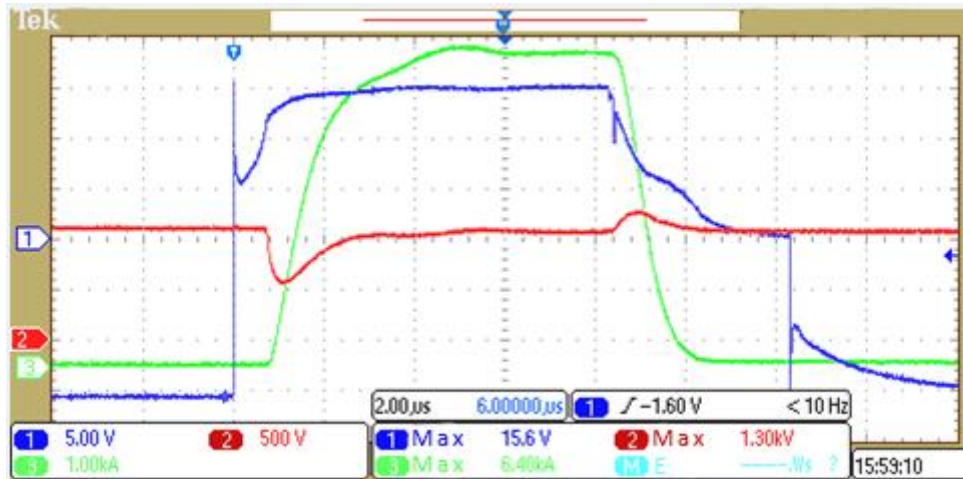

Fig.7 Short-circuit waveform of FF1400R17IP4 at 1100V

In the picture above, CH1: V_{GE} (blue); CH2: V_{CE} (red); CH3: I_C (green).

Fig.7 shows the short-circuit waveform of the 1700V/1400A IGBT (FF1400R17IP4) controlled by the Firstack IGBT driving circuit when the DC bus is 1100V. The peak value of short-circuit current is 6400A(4.5 times of rated current). Under the action of soft shut down, I_C drops slowly, V_{CE} has almost no overshoot, and IGBT is safely turned off.

◆ Digitally dynamic advanced active clamping D^2A^2C technology

When the system is overloaded or short-circuited on the load side, the turn-off current of the IGBT will increase significantly. Under these conditions, active clamping can protect the IGBT and avoid failures caused by turn-off overvoltage.

When the V_{CE} voltage exceeds the TVS threshold, the TVS is broken down and the current sinks into the gate, which makes the V_{GE} rise and the IGBT enters the linear region, thereby limiting the turn-off voltage within a safe range.

In order to improve the clamping effect, Firstack introduced a digitally controlled active clamping and added a

"digitally controlled current source" to the gate. When the current I_z flowing through the TVS is larger than a certain threshold, the N IGBT is turned off and the "digitally controlled current source" is started at the same time. At this time, $I_z = I_G + I_D$, through the digitally controlled current source, keeping I_z at a low value, the TVS has been in a weak breakdown state until the end of the turn-off.

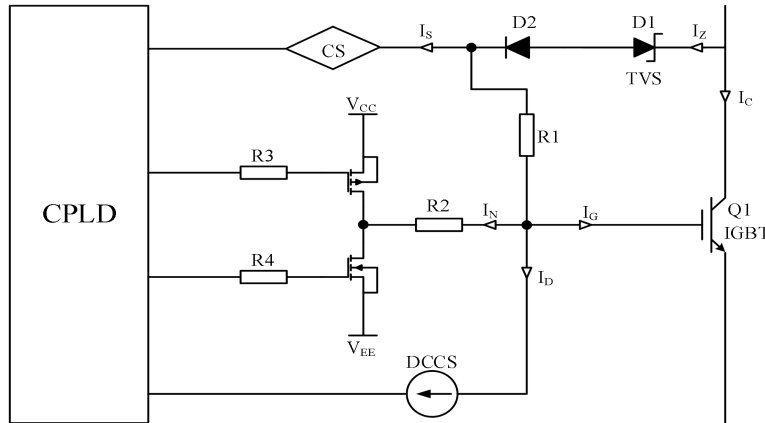

Fig.8 Schematic diagram of active clamping principle

The following Fig.9 is the short-circuit test waveform of intelligent gate driver products based on Infineon FF1000R17IP4 module. The turn-off moment V_{ce} voltage is basically clamped at 1380V, and the turn-off process is very smooth with no violent oscillation.

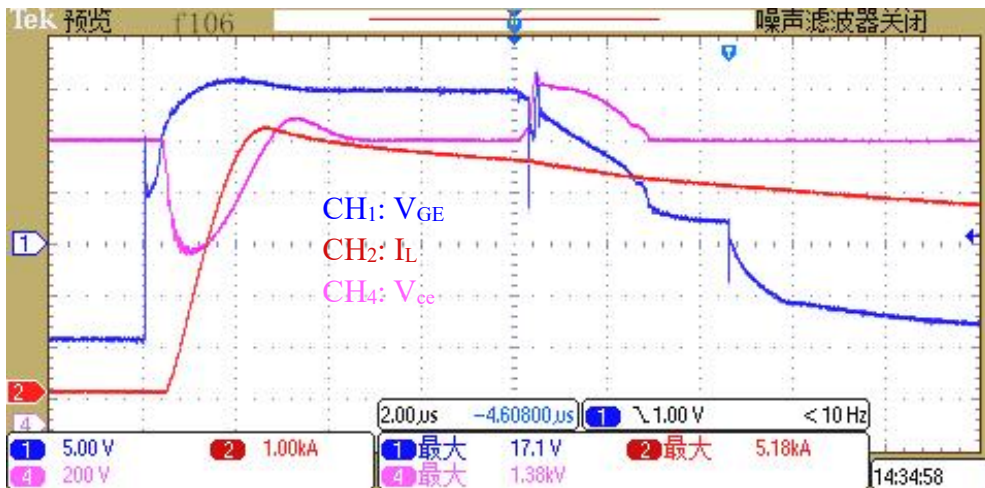

Fig.9 Digitally controlled active clamping waveform

In the picture above, CH1: V_{GE} (blue); CH2: I_C (red); CH4: V_{CE} (pink).

◆ **Multi-level turn-off**

In some applications with large stray inductances, such as NPC I-type 3-level large commutation circuit, IGBT will face the risk of high turn-off peak every time it is turned off. Because of the limitation of the thermal capacitance of TVS, active clamping technology is not suitable for these occasions, and the multi-level turn-off technology can play a significant role at this time. By using different turn-off resistances in the turn-off process, the entire turn-off process can be optimized and the turn-off spike can be suppressed.

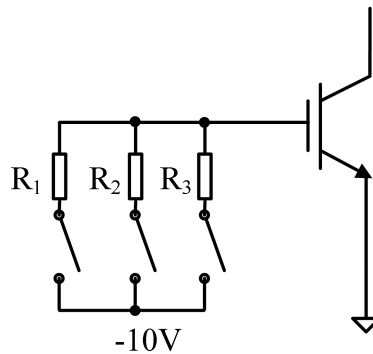

Fig.10 Multi-level turn-off schematic

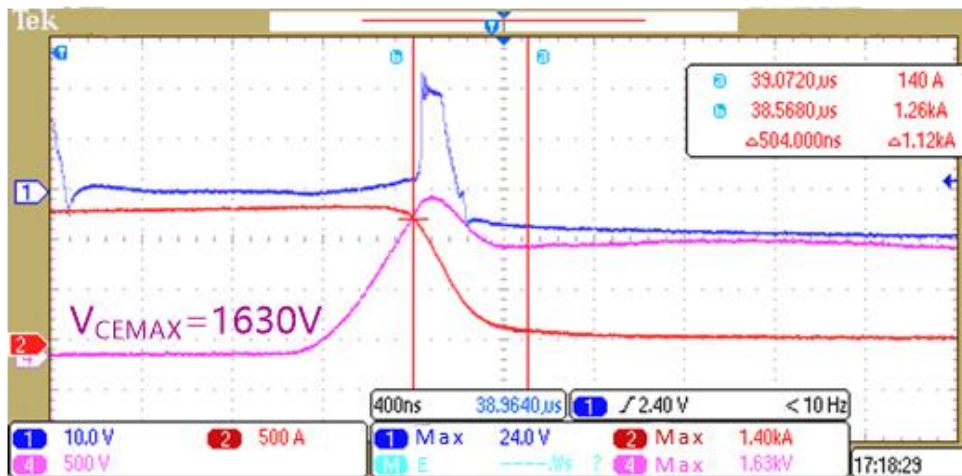

Fig.11a Without multi-level turn-off

In the picture above, CH1: V_{GE} (blue); CH2: I_C (red); CH4: V_{CE} (pink)

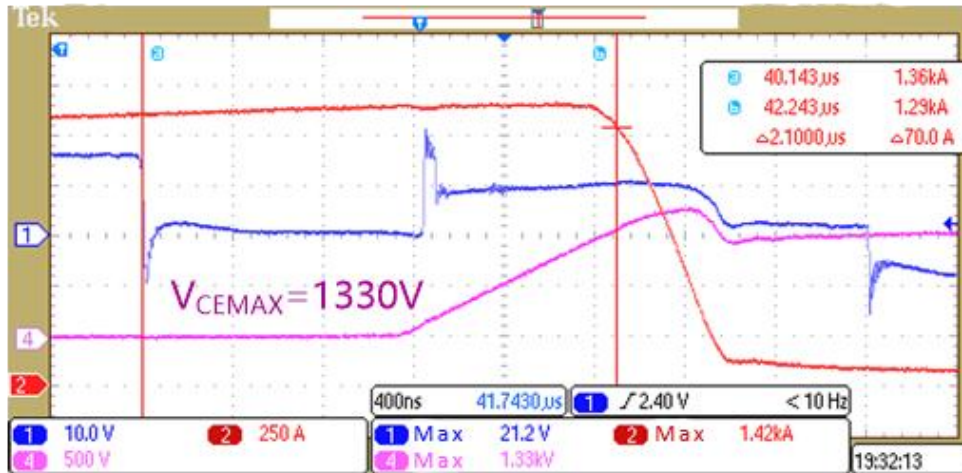

Fig.11b With multi-level turn-off

In the picture above, CH1: V_{GE} (blue); CH2: I_C (red); CH4: V_{CE} (pink).

◆ **Highly robust DC/DC**

Since the built-in DC/DC of the gate driver needs to reduce the coupling capacitance C_{PS} of the primary and secondary side as much as possible, it generally adopts an open-loop form, so it is difficult to integrate functions such as overcurrent protection, which also leads to the anti-overload of the built-in DC/DC ability very poor.

In order to improve the reliability of the gate driver, Firstack puts forward the concept of "highly robust DC/DC".

Under the premise of keeping the open-loop, the gate driver can withstand a GE short-circuit.

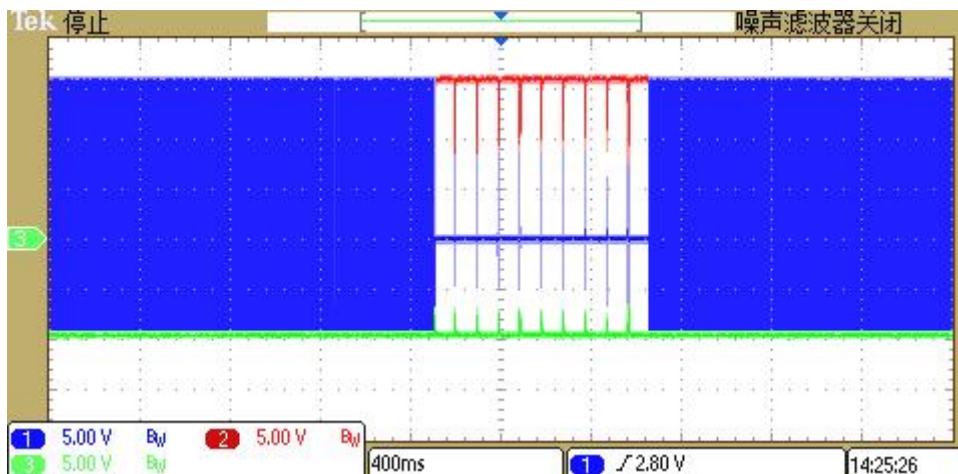

Fig.12 GE waveform

In the picture above, CH1: V_{GE} (blue); CH2: I_C (red)=+15V(secondary side); CH3: V_{CE} (green)=-10V (secondary side)

When an overload occurs, the gate driver will block the PWM signal and report a fault signal to the master computer at the same time. When the overload is removed, the gate driver will return to its normal state.

Note: When the gate resistance is small, or the gate resistance is too large ($>10\Omega$), this function may not be applicable.

◆ Fiber optic port notification signal

In the process of using fiber optic, there are some phenomena, such as the buckle of fiber optic port is not firm/falling off, and the turning radius of fiber optic line is not enough. In order to ensure the normal fiber optic communication, the Firststack intelligent gate driver is configured with the fiber port response function, as follows:

1. When the gate driver board operates normally, every time a PWM command is received, the light of the returning fibre optic head will turn off for a short time of 700ns at the rising edge and falling edge of the PWM command as a response to receiving the command.

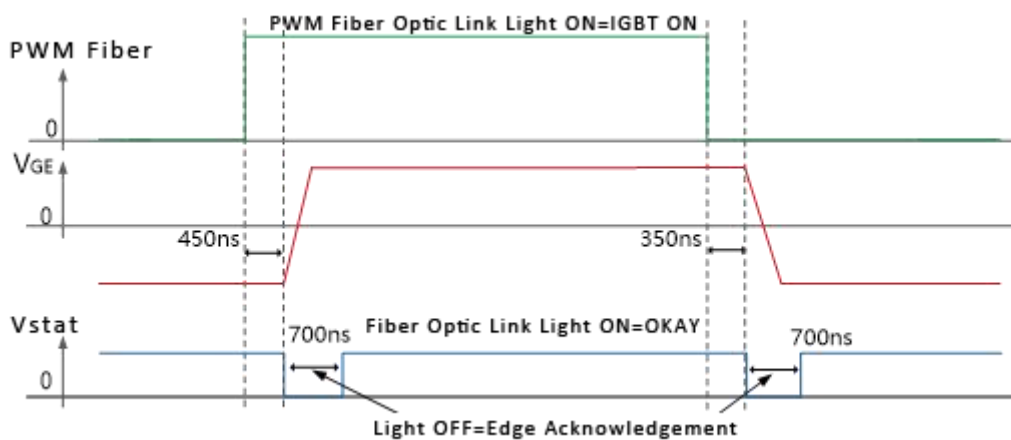

Fig.13a Normal condition

2. When the fault is detected by the gate driver board, the light of the returning fibre optic head will go out for more than 30us, which will be used as a fault signal to inform the master computer.

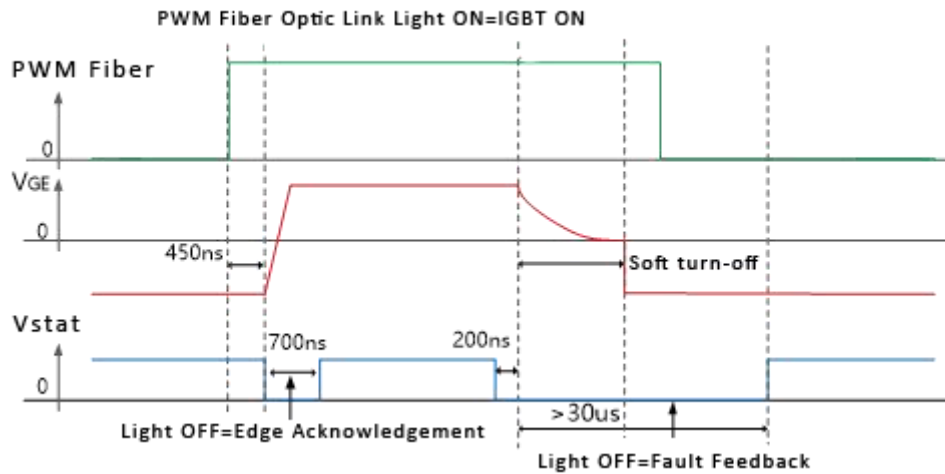

Fig.13b Fault condition

The master computer can accurately distinguish the response information from the fault information by the length of time for the light of the returning fiber optic head going out.

Gate resistor indication

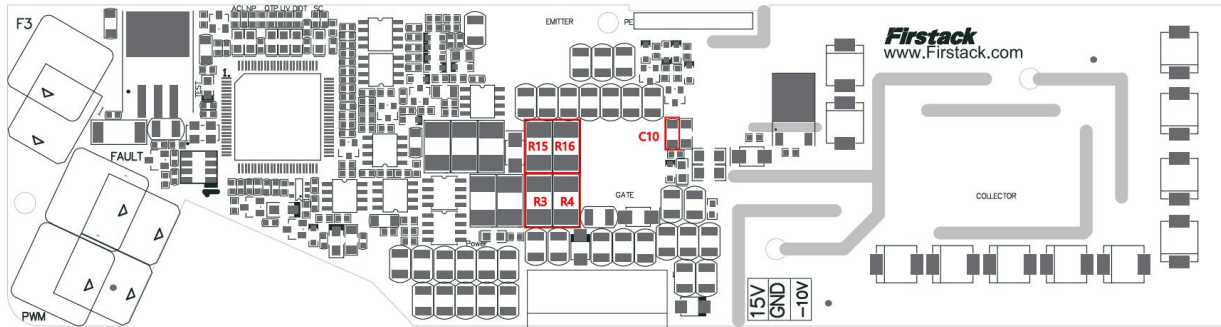

Fig.14 Gate resistor indication

Calculation formula of gate resistor

	Rgon	Rgoff	Cge
Single IGBT	R3//R4	R15//R16	C10

Gate driver model selection of common IGBT modules

IGBT model	Gate driver model selection	Cge (nF)	Rgon (Ω)	Rgoff (Ω)
ALL 4500V IHV model	HV1027P-2V-45-A1	NC	NC	NC
ALL 6500V IHV model	HV1027P-2V-65-A1	NC	NC	NC
FZ1200R45KL3_B5	HV1027P-2V-FZ1200R45KL3	NC	1.8	$\approx 6^*$
YMIF1200-45	HV1027P-2V-5SNA1200G450300	220	1.8	$\approx 5^*$
TIM1200ASM45-PSA011	HV1027P-2V-5SNA1200G450300	220	1.8	$\approx 5^*$
5SNA1200G450300	HV1027P-2V-5SNA1200G450300	220	1.8	$\approx 5^*$
CM1200HG-90R	HV1027P-2V-5SNA1200G450300	220	1.8	$\approx 5^*$
5SNA1500G450350	HV1027P-2V-5SNA1200G450300	220	1.8	$\approx 5^*$
5SNA0800J450300	HV1027P-2V-5SNA1200G450300	220	1.8	$\approx 5^*$
MBN1200H45E2-H	HV1027P-2V-MBN1200H45E2-H	NC	5	$\approx 5^*$
MBN800H45E2-H	HV1027P-2V-MBN1200H45E2-H	NC	5	$\approx 6^*$
MBN1500FH45F-H	HV1027P-2V-MBN1500FH45F-H	NC	5	$\approx 10^*$
TIM1500A2SM45-TSA000	HV1027P-2V-TIM1500A2SM45-TSA000	220	1.8	$\approx 6^*$
FZ800R45KL3_B5	HV1027P-2V-FZ800R45KL3_B5	220	1.8	$\approx 6^*$
TIM800XSM45-PSA011	HV1027P-2V-FZ800R45KL3_B5	220	1.8	$\approx 6^*$
CM800HG-90R	HV1027P-2V-CM800HG-90R	NC	5	$\approx 20^*$
TIM1200ASM45-PSA012	HV1027P-2V-476Z-TIM1200ASM45-PSA012	220	1.8	$\approx 6^*$
DIM1200ASM45-TF001	HV1027P-2V-DIM1200ASM45-TF001	220	3.1	$\approx 6^*$

Note:

1. We strongly recommend that customers prioritize these models and the corresponding gate parameters, which have been fully validated, ships in large quantities and has significant advantages in delivery time.
2. * is equivalent gate turn-off resistance, these drive models use multi-level turn-off technology, the specific turn-off characteristics are subject to actual testing.
3. The application of the above gate parameters requires a busbar inductance of less than 200nH;
4. Recommended dead time of inverter controller for normal operation $\geq 8\mu\text{s}$;
5. If the customer thinks that an IGBT module parameter is not suitable in our recommended list, we recommend customers to use models without resistor, including the test phase and batch phase, which has significant advantages both in price and delivery time. They are HV1027P-2V-45-A1 and HV1027P-2V-65-A1. These model requires the customer to weld the gate resistance and apply three proof paint themselves. For details, please refer to our company's instruction manual "IGBT Driver General Model SMT Gate Resistance Welding Instruction Manual".

Ordering Information

HV1027P can support IHV modules of different models from multiple manufacturers. If you have a purchase request, please contact us, and we can provide the gate driver that best meets your needs.

Technical Support

Firstack's professional team will provide you with business consultation, technical support, product selection, price, lead time and other related information, and guarantee to answer your questions within 48 hours.

Legal Disclaimer

This manual gives a detailed introduction about the product, but cannot promise to provide specific parameters. No warranty or guarantee, express or implied, is given herein as to the delivery, performance or applicability of the product.

Firstack reserves the right to modify technical data and product specifications at any time without prior notice. Firstack's general payment terms and conditions apply.

Contact Information

Tel: +86-571 8817 2737

Fax: +86-571 8817 3973

Website: www.firstack.com

Email: fsales@firstack.com

Address: 4-5/F, Building/5, Xizi Wisdom Industrial Park, No.1279 Tongxie Road, Hangzhou, China