

2FHC06M17A1 Data Sheet

Abstract

The 2FHC06M17A1 is a high-performance, dual-channel SiC gate driver developed based on intelligent chip technology by Firstack. It supports SiC modules up to 1700V. The 2FHC06M17A1 can be used individually or in combination, connected by a set of cables, easily parallelise SiC modules with configurable gate voltages for single modules in the EconoDual™ package or 2 in parallel. The architecture is able to safely and reliably drive the SiC modules with high flexibility and system scalability.

Highlights:

- Support multiple parallel connections of modules
- Support up to 1700V module
- Digital control method
- Short-circuit protection(soft shut down)
- Miller clamp
- Configurable drive voltage
- Intelligent fault feedback
- Undervoltage protection

Applications:

- Motor drives
- ESS
- Rail



Fig.1 2FHC06M17A1

Functional Block Diagram

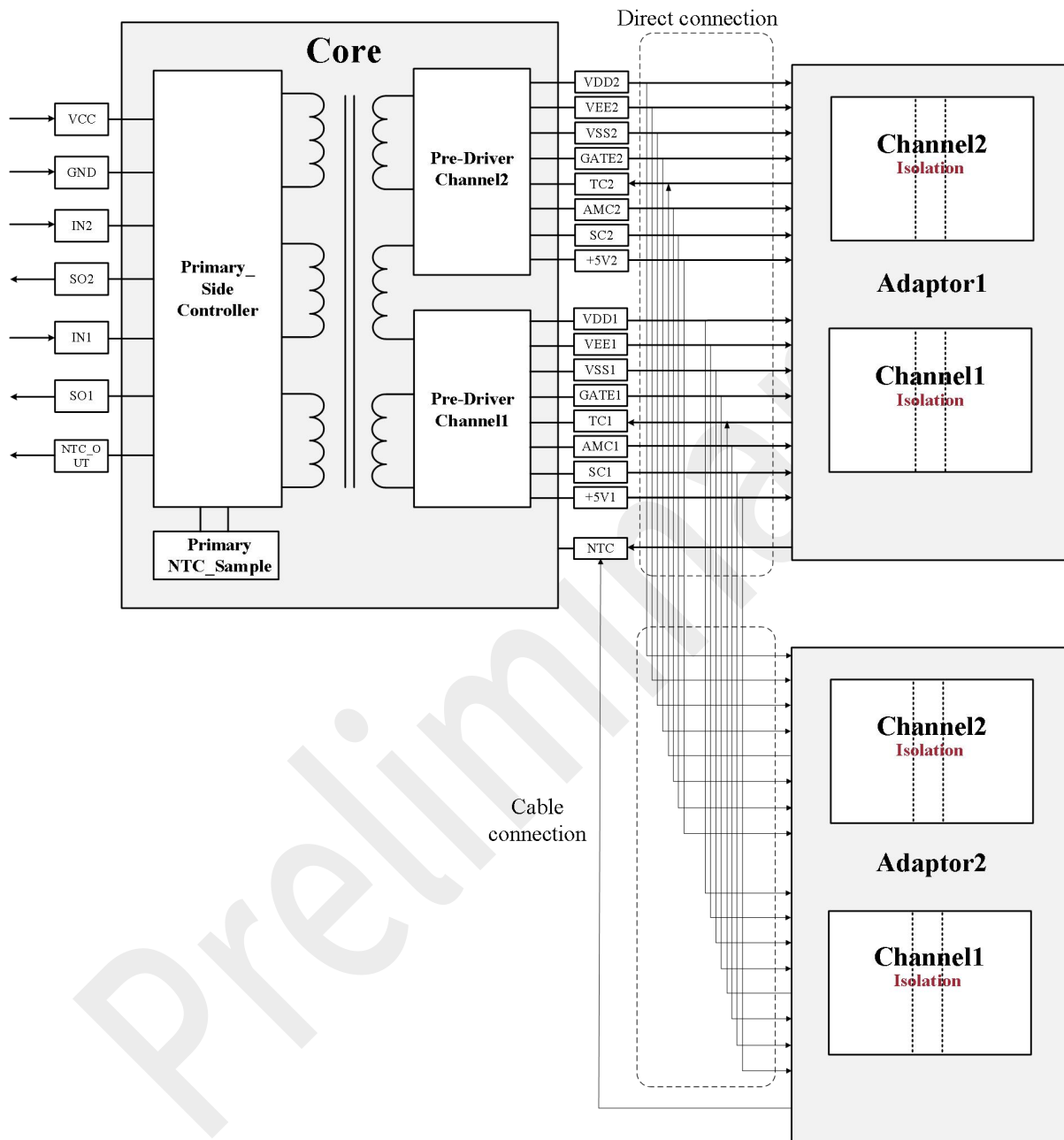

Fig.2 Functional block diagram

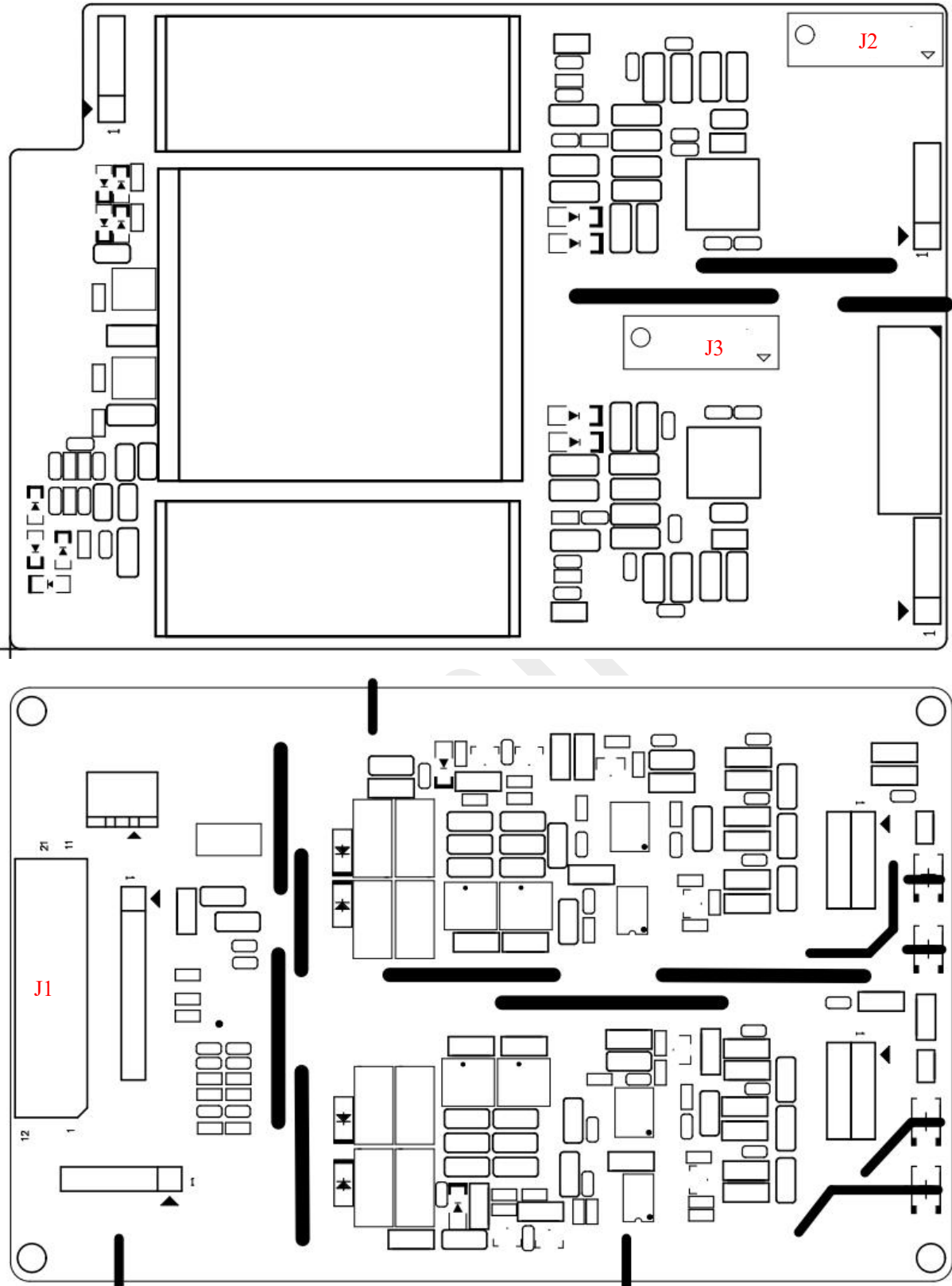
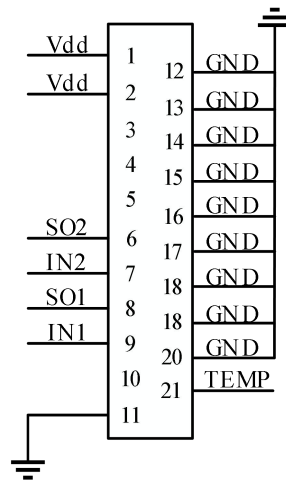

Fig.3 PCB schematic

Connector Interface Definition



J1 terminal pin designation

Pin	Definition	Function	Pin	Definition	Function
1	V _{DD}	Power supply input	12	GND	Primary side ground
2	V _{DD}	Power supply input	13	GND	Primary side ground
3	NC	Free	14	GND	Primary side ground
4	NC	Free	15	GND	Primary side ground
5	NC	Free	16	GND	Primary side ground
6	SO2	Status output channel 2	17	GND	Primary side ground
7	IN2	Signal input channel 2	18	GND	Primary side ground
8	SO1	Status output channel 1	19	GND	Primary side ground
9	IN1	Signal input channel 1	20	GND	Primary side ground
10	NC	Free	21	TEMP	NTC sampling
11	GND	Primary side ground			

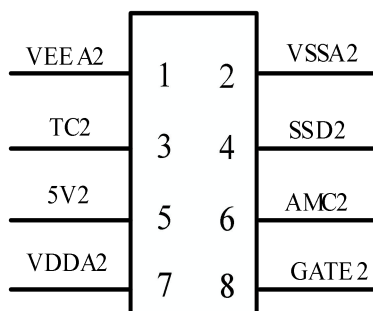

J2 terminal pin designation

Pin	Definition	Function	Pin	Definition	Function
1	VEEA2	Secondary channel 2 side ground	2	VSSA2	Secondary side negative supply channel 2
3	TC2	Short-circuit detection signal channel 2	4	SSD2	Soft shut down signal channel 2
5	5V2	Secondary side 5V supply channel 2	6	AMC2	Miller clamp signal channel 2
8	VDDA2	Secondary side positive supply channel 2	9	GATE2	Gate drive signal channel 2

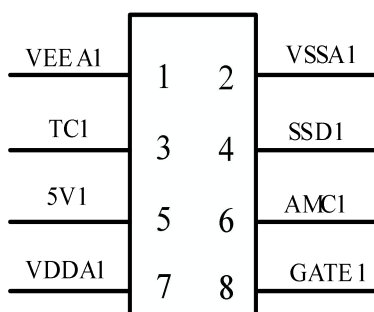

J3 terminal pin definition

Pin	Definition	Function	Pin	Definition	Function
1	VEEA1	Secondary channel 1 side ground	2	VSSA1	Secondary side negative supply channel 1
3	TC1	Short-circuit detection signal channel 1	4	SSD1	Soft shut down signal channel 1
5	5V1	Secondary side 5V supply channel 1	6	AMC1	Miller clamp signal channel 1
7	VDDA1	Secondary side positive supply channel 1	8	GATE1	Gate drive signal channel 1

Technical Parameters

Absolute Maximum Ratings

Parameter	Remarks	Min	Max	Unit
Supply voltage V_{DC}	V_{DC} to GND	0	15.5	V
Gate peak current	@85°C	-15	20	A
Output power per channel	@85°C		6	W
Test voltage (50Hz/1min)	Primary to secondary side	5000		V_{RMS}
Operating temperature		-40	85	°C
Storage temperature		-40	90	°C

Recommended Operating Conditions

Parameter	Remarks	Min	Typ	Max	Unit
Supply voltage V_{DC}	V_{DC} to GND	14.5	15	15.5	V
Supply current I_{DC}	Without load		0.12		A
Coupling capacitor C_{IO}	Primary to secondary side		/		pF
Primary side undervoltage threshold	Supply voltage		12		V
Secondary side undervoltage threshold	Secondary side positive voltage		12.5		V

Gate Driver Parameters

Output level	Remarks	Min	Typ	Max	Unit
Total gate voltage	Turn on (ON)- off (OFF) voltage	19.5	22	24.5	V
Gate positive voltage V_{GSon}	Turn on (ON)	14.5	18	19.5	V
Gate negative voltage V_{GSoff}	Turn off (OFF)	-9.5	-4	-0.5	V

Logic Inputs & Outputs

Parameter	Remarks	Min	Typ	Max	Unit
Input signal INx	INx to GND	14.5	15	15.5	V
Input impedance			100		kΩ
Turn-on threshold	V(INx)	9.2			V
Turn-off threshold	V(INx)			3.2	V
Fault output SOx	Protection state @Io<10mA			0.35	V
MOD mode	Direct mode	Set by software, no configuration required			
	Half-bridge mode	Set by software, no configuration required			

Short-circuit protection

Parameter	Remarks	Min	Typ	Max	Unit
V _{DS} monitoring threshold	Short-circuit protection monitoring	Configurable	11	Configurable	V
Response time	CH1, Note 1	Configurable	1.2	Configurable	μs
	CH2, Note 1	Configurable	1.2	Configurable	μs
Soft shut down time	Soft shut down action time	Configurable	6.24	Configurable	μs

Miller Clamp

Parameter	Remarks	Min	Typ	Max	Unit
Time from drive signal turn-off to clamp turn-on		Configurable	500	Configurable	ns
Time from clamp turn-off to drive signal turn-on			500		ns
Clamp voltage			VSS (negative voltage)		

Timing Characteristics

Parameter	Remarks	Min	Typ	Max	Unit
Turn-on delay	Note 2		1.2		μs
Turn-off delay	Note 3		1.3		μs
Rise time	Note 4		12		ns
Fall time	Note 5		12		ns
Fault blocking time			80		ms
Fault return time	Note 6		10		ms

Electrical Isolation

Parameter	Remarks	Min	Typ	Max	Unit
Creepage distance	Primary to secondary side, Note 7		29		mm
	Secondary to secondary side, Note 7		25		mm
Clearance distance	Primary to secondary side		12.5		mm
	Secondary to secondary side		6		mm

Unless otherwise specified, all data are based on tests at +25°C ambient temperature and $V_{DC}=15V$.

Note:

1. Response time: the time from the occurrence of the fault to the start of soft shut down;
2. Turn-on delay: the time required to transmit the rising edge of the PWM signal input from the primary side to the rising edge of the secondary side of the gate driver;
3. Turn-off delay: the time required to transmit the falling edge of the PWM signal input from the primary side to the falling edge of the secondary side of the gate driver;
4. Rise time: the amount of time from 10% of the gate turn-off voltage (-4V) to 90% of the gate turn-on voltage (+18V);
5. Fall time: the amount of time from 90% of the gate turn-on voltage (+18V) to 10% of the gate turn-off voltage (-4V);
6. Fault return time: the fault hold time under SC fault;

7. Creepage distance: refer to IEC61800-5-1-2007, and meet the basic isolation requirements of below 2km altitude and pollution level 2; this value is the creepage distance of the isolation device.
8. The specific NTC temperature should be matched according to the module used.

NTC Sampling Data Example:

Duty Cycle (%)	Rntc (kΩ)	Duty Cycle (%)	Rntc (kΩ)
85.82	99.09	46.74	1.52
85.48	75.14	43.40	1.30
85.02	57.53	40.18	1.12
84.48	44.45	37.06	0.97
83.80	34.61	34.08	0.84
82.98	27.16	31.26	0.73
81.98	21.48	28.62	0.64
80.80	17.12	26.14	0.56
79.42	13.73	23.86	0.49
77.80	11.08	21.76	0.44
75.96	9.00	19.82	0.39
73.86	7.36	18.06	0.34
71.54	6.05	16.44	0.30
68.96	5.00	14.98	0.27
66.18	4.16	13.64	0.24
63.22	3.47	12.42	0.22
60.08	2.91	11.32	0.20
56.80	2.46	10.32	0.18
53.48	2.08	9.42	0.16
50.10	1.77		

3D and Mechanical Dimensions

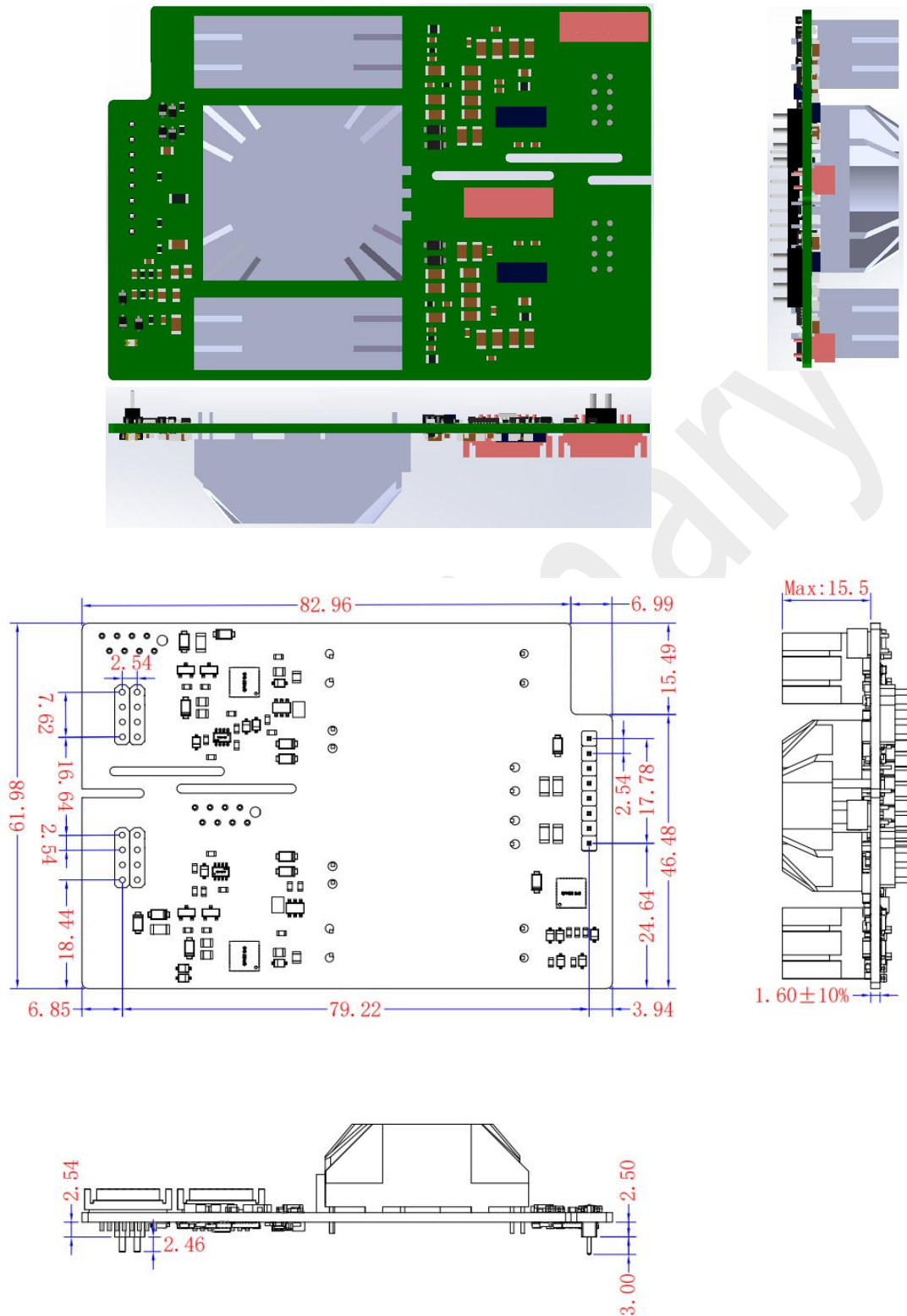

Fig.4 3D and mechanical dimensions (unit: mm)

Note: 1. The thickness tolerance of the board is ±10%;

2. Other dimensional tolerances refer to GB/T1804-m.

Ordering Information

The 2FHC06M17A1 can support different models of packaged modules from multiple manufacturers. If you have a purchase request, please add the module part number after the gate driver part number so that we can provide the gate driver that best meets your needs.

Technical Support

Firstack's professional team will provide you with business consultation, technical support, product selection, price, lead time and other related information, and guarantee to answer your questions within 48 hours.

Legal Disclaimer

The instruction manual provides a detailed description of the product but does not commit to providing specific parameters regarding the delivery, performance, or applicability of the product. This document does not offer any express or implied warranties or guarantees.

Firstack reserves the right to modify technical data and product specifications at any time without prior notice. The general delivery terms and conditions of Firstack apply.

Contact Information

Tel: +86-571 8817 2737

Fax: +86-571 8817 3973

Website: www.firstack.com

Email: fsales@firstack.com

Address: 4-5/F, Building/5, Xizi Wisdom Industrial Park, No.1279 Tongxie Road, Hangzhou, China