

2FHD0320C

Application Manual

Electrical interface driver solution for PrimePACK™ module, supports multi-level

The 2FHD0320C is the dual-channel gate driver with optical interface. The gate driver comes with ASIC digital control, which can drive IGBTs safely and reliably. The gate drivers are suitable for Infineon PrimePACK™ as well as other brands of IGBTs in the same package. The plug-and-play gate driver can be assembled and used directly without further development.

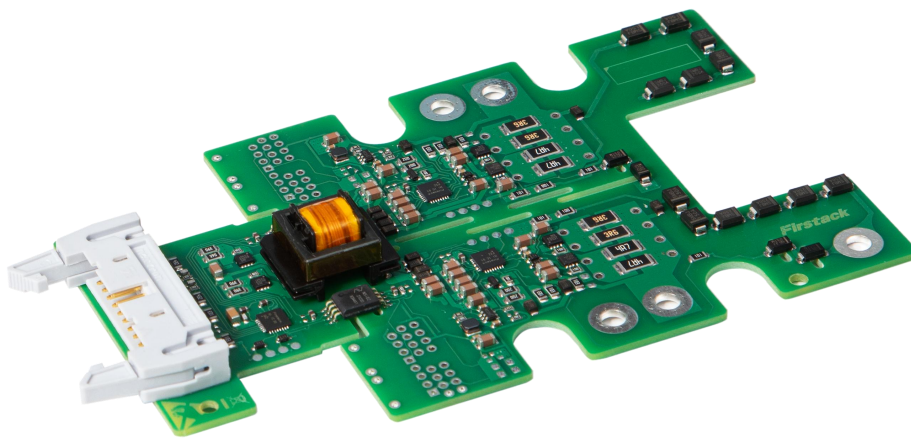

Fig.1 2FHD0320C

Contents

Driver Overview	3
Use steps and safety notice	4
Recommended application circuits of 2FHD0320C	6
Description of Connector P1 Interface	7
1. Overview	7
2. VCC/VDC	7
3. IN _x	7
4. SO _x	8
Technical Principle	11
1. Function Overview	11
2. Power Supply and Electrical Isolation	11
3. Power Monitoring	11
4. Short-Circuit Protection	12
5. Soft Shut Down	13
6. Active Clamping	14
7. Intelligent Fault Management	14
Technical Support	15
Legal Disclaimer	15
Company Information	15

Driver Overview

The 2FHD0320C is the plug-and-play gate driver developed by Firstack based on digital control, the functional block diagram is shown in **Fig.2**, and the values of the gate resistors and other key components can be found in the data sheet of the corresponding gate driver.

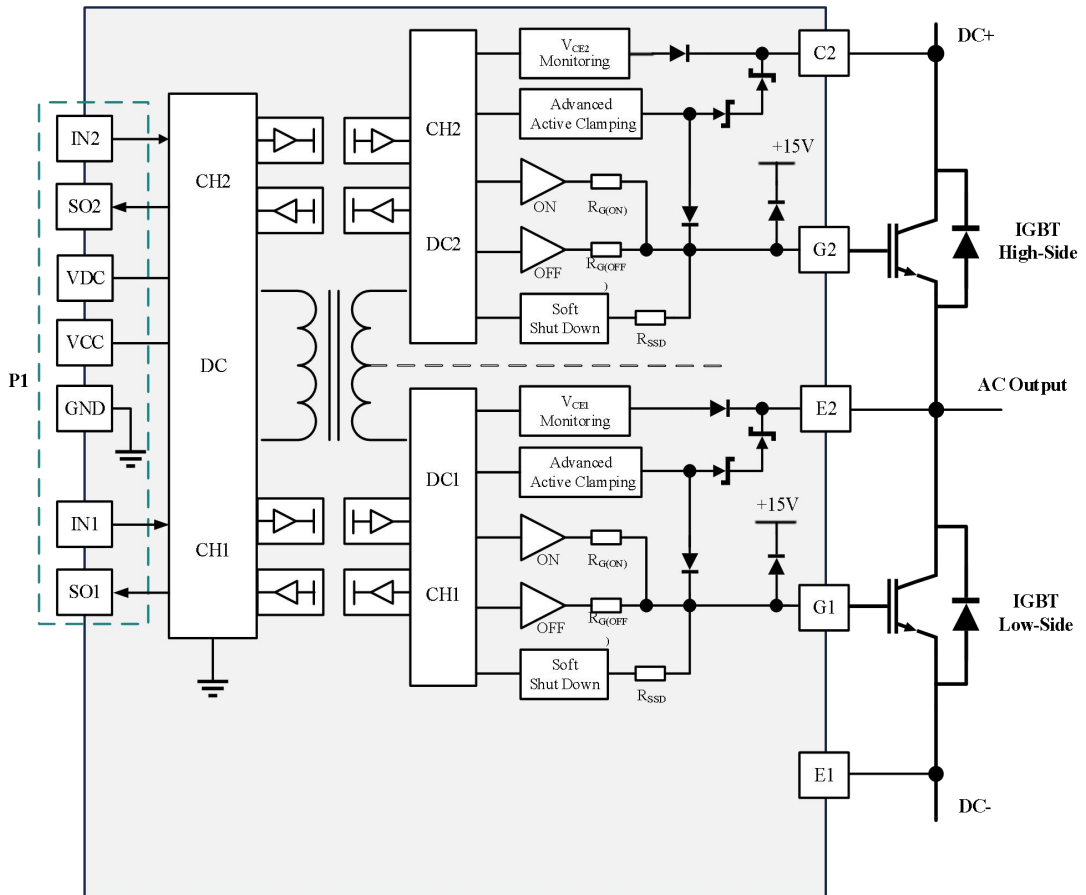

Fig.2 Functional block diagram

The gate driver has the built-in input connector P1, isolated DC/DC power supply, driving circuit, integrates Vce detection (short-circuit protection), undervoltage protection, active clamping, soft shut down and other functions, which can drive IGBT modules safely and reliably.

Use steps and safety notice

Simple use steps of the gate driver are as follows:

1. Choose suitable gate driver

When using the gate driver, pay attention to the model of the IGBT module that the gate driver is adapted to. It is invalid for non-designated IGBT modules. Improper use may cause the gate driver and the module failure.

2. Install the gate driver on the IGBT module

Any treatment of IGBT modules or gate drivers should follow the general specifications for the protection of electrostatic sensitive devices required by the international standard IEC 60747-1, Chapter IX or IEC 60340-5-2 (which means the workplace, tools, etc. must comply with these standards).

If these specifications are ignored, both the IGBT and the gate driver may be damaged.



3. Connect the gate driver to the control unit

Connect the gate driver connector to the control unit and provide a suitable power supply voltage for the gate driver.

4. Check the function of the gate driver

Check the gate voltage: for the turn-off state, the rated gate voltage is given in the corresponding data sheet, for the turn-on state, the voltage is 15V. Please also check the input current of the gate driver with and without a control signal.

These tests should be performed before installation, because the gate terminal may not be accessible after installation.

5. Set up and test the power unit

Before starting the system, it is recommended to check each IGBT module with a single pulse or

double pulse test method. Firstack specially reminds: even under the worst conditions, it is necessary to ensure that the IGBT module does not exceed the operating range specified by SOA, because the operating condition of the IGBT module strongly depends on the specific converter architecture.

Even when testing a single IGBT, power must be supplied to the remaining gate drivers in the system to ensure that the gates of all other IGBTs operate in negative voltage turn-off state. This is particularly important when testing the switching behaviour of the IGBT.

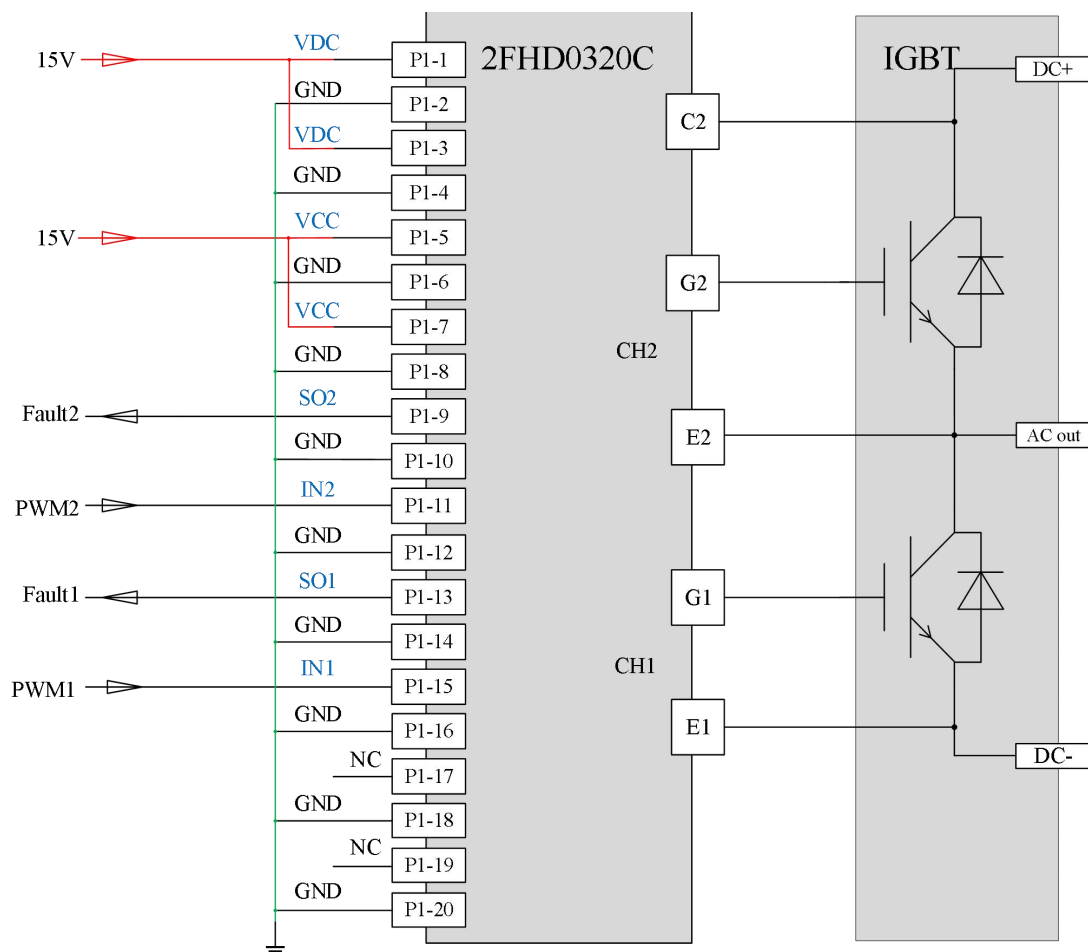
Recommended application circuits of 2FHD0320C

P1 Connector Pin Designation

Pin	Definition	Function	Pin	Definition	Function
1	VDC	For DC/DC power supply +15V	2	GND	Primary side ground
3	VDC	For DC/DC power supply +15V	4	GND	Primary side ground
5	VCC	For primary side power supply +15V	6	GND	Primary side ground
7	VCC	For primary side power supply +15V	8	GND	Primary side ground
9	SO2	Top IGBT fault return(high normal, low fault)	10	GND	Primary side ground
11	IN2	Top IGBT driver input signal(high turn on, low turn off)	12	GND	Primary side ground
13	SO1	Bottom IGBT fault return(high normal, low fault)	14	GND	Primary side ground
15	IN1	Bottom IGBT driver input signal(high turn on, low turn off)	16	GND	Primary side ground
17	NC	Free	18	GND	Primary side ground
19	NC	Free	20	GND	Primary side ground

Description of Connector P1 Interface

1. Overview

The P1 interface circuit of the 2FHD0320C gate drivers is simple and easy to use.

The P1 connector of the gate drivers is equipped with the following pins:

- 4× power inputs(only need a 15V power supply)
- 2× driving signal inputs
- 2× fault signal outputs
- 10× GND(ground)
- 2× NC(Free)

The gate driver comes with a 20-pin interface connector, all even pins are set as GND and odd pins are set as inputs or status outputs. The 20-pin twisted flat cable is recommended. Each input and output signal line are twisted with the corresponding GND line. All GND pins are connected together on the 2FHD0320C, and should be connected to the control board side. This configuration reduces parasitic inductance while increasing immunity.

2. VCC/VDC

The gate driver has two VCC and two VDC power supply terminals on the P1 connector for the primary side circuit and isolated DC/DC supply. All VCC and VDC terminals must be connected to a single 15V supply for power. the VDC and VCC terminals are split into separate pins for testing purposes only.

The total power of the gate driver is 6W, and based on 80% efficiency, 15V requires an input current of 500mA to limit the start-up impulse current.

3. INx

The input signal pin of the gate driver supports 5~15V logic voltage, the function of INx is related to the mode set by the gate driver, the software can set the mode of the gate driver, the hardware

can not be set. 2FHD0320CxxAx and 2FHD0320CxxBx are the direct mode, and 2FHD0320CxxDx is the half-bridge mode. Please select the corresponding gate driver part number for the drive signal mode of the main control panel.

Direct mode:

IN1 and IN2 are independent of each other and are both signal input for the corresponding channel, channel 1 and channel 2 can be turned on at the same time. In half-bridge applications, it is necessary to ensure that there is sufficient dead time between IN1 and IN2.

Half-bridge mode:

In this mode, IN1 is the drive signal input (PWM), IN2 is the signal input enable terminal (EN); if IN2 is low, the output signals of both channels are blocked, if IN2 changes from low to high, the two output channels are enabled and the output signals change with the input signal (PWM). In the half-bridge mode, channel 1 and channel 2 will not turn on at the same time, the default setting of dead time is 4us, software can be customized.

The half-bridge mode logic is shown as below:

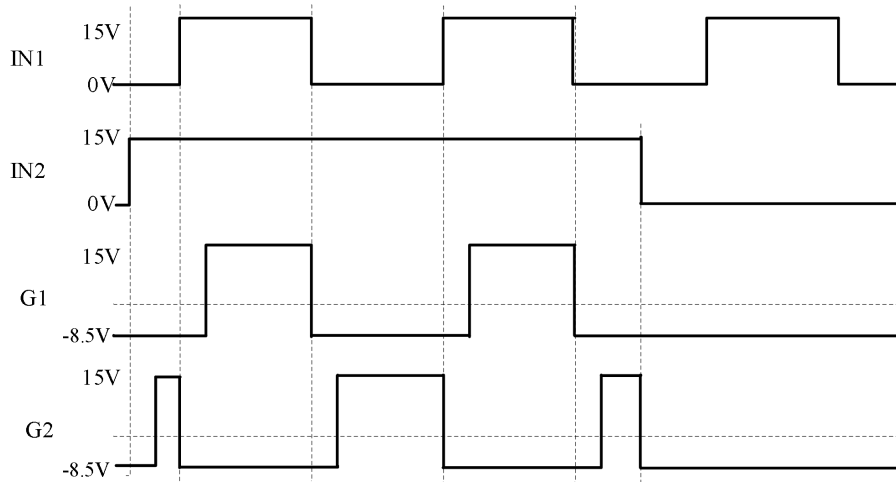

Fig.3 Half-bridge mode logic diagram

4. SOx

The output SOx have open-drain transistors, separate fault signal is recommended to pinpoint the problem. They can also be connected together to provide common fault signal.

Under fault state, the current flowing through SOx can not exceeds he maximum value specified in the data sheet.

SOx is in open-drain mode(OD)

When no fault is detected, the output is in high resistance state, it is necessary to connect a pull-up resistor at the other terminal of the cable, the pull-up voltage is recommended to be 5~15V.

When channel 'x' detects a fault, the status output SOx terminal is pulled low (connected to GND).

SOx is in pull-up mode

When no fault is detected, the output is 15V. The gate driver is internally pulled up through a 10K resistor, so when external SOx external resistor is connected, impedance matching needs to be paid attention to, which can avoid voltage dividing leading to system misjudgment.

When channel 'x' detects a fault, the status output SOx terminal is pulled low (connected to GND).

SOx output logic

When an undervoltage fault occurs in the primary side of the gate driver, the gate performs soft shut down, then puts in a negative voltage to keep the turn-off state and keep blocking for a blocking time, at the same time both of SOx goes to high after reporting 40ms low level fault. If the undervoltage disappears before the above process, SOx will keep high. If the undervoltage still occurs, the fault will be pulled down again until the fault disappears, then return to high after a blocking time (80ms).

When an undervoltage fault occurs in the secondary side of the gate driver, the gate performs soft shut down first, then puts in a negative voltage to keep the turn-off state and keep blocking for a blocking time, the corresponding SOx goes to high after reporting 20ms low level fault. If the undervoltage disappears before the above process, SOx will keep high. If the undervoltage still occurs, the fault will be pulled down again until the fault disappears, then return to high after a blocking time (80ms).

When a short-circuit fault occurs in the secondary side of the gate driver, the gate performs soft shut down first, then puts in a negative voltage to keep the turn-off state and keep blocking for a blocking time, the corresponding SOx goes to high 70ms after reporting 10ms low level fault. If

the short-circuit disappears before the above process, SOx will keep high. If the short-circuit still occurs, the fault will be pulled down again until the fault disappears, then return to high after a blocking time (80ms).

The 2FHD0320C is equipped with the intelligent fault management function, please refer to the following for details.

Technical Principle

1. Function Overview

The 2FHD0320C plug-and-play gate driver is developed for IGBT modules in PrimePACK™ or the same package.

Basic functions: signal isolation, DC/DC power isolation.

Protection functions: short-circuit protection, undervoltage protection, soft shut down, active clamping, fault blocking, status feedback.

Digital function: intelligent fault management.

The gate drivers support for direct driver paralleling and multi-level applications.

2. Power Supply and Electrical Isolation

This gate driver implements isolated power and signal. Power isolation is realized by the transformer, signal isolation is realized by capacitive coupling. The transformer complies with the safety isolation standard EN50178 and the primary and secondary sides fulfil protection class 2.

Please note that a stable supply voltage and current are required to power the driver.

3. Power Monitoring

The primary side, as well as the two secondary side power supplies of the gate driver have local power detection circuits, and corresponding undervoltage protection.

When undervoltage occurs in the primary side power supply, both IGBTs are driven by the negative gate voltage to maintain the turn-off state (both channels are blocked), SO1 and SO2 feed back the fault status signal to the master computer, and both secondary side fault fibre-optics feed the fault status signals back to the master computer.

When the positive or negative voltage on the secondary side is lower than the threshold voltage, the driver circuit will determine that an undervoltage fault has occurred, the driver circuit will automatically block the IGBT, and the corresponding SOx will feedback a fault signal to the

master computer.

The SO output terminal can automatically reset after the primary and secondary side undervoltage faults are removed and a corresponding fault returning time(refer to intelligent fault management).

Firstack recommends against operating either IGBT in the bridge arm in an undervoltage state.

1. Due to the presence of C_{CG} , when one IGBT in the bridge arm turns on, the high dv/dt from it can be coupled to the other IGBT through the C_{CG} , resulting in micro-conductance of the other IGBT.
2. Undervoltage on the primary and secondary side results in a lower gate voltage, which in turn causes an increase in IGBT switching losses.

4. Short-Circuit Protection

The driving circuit judges whether the IGBT is in a short-circuit state by detecting the collector voltage V_{CE} when the IGBT is turned on.

The collector voltage is detected by high voltage diode. When the V_{CE} voltage exceeds the set threshold, the gate driver determines that the IGBT is in a short-circuit state, starts the soft shut down to slowly turn the IGBT off, and returns the fault to the master computer at the same time.

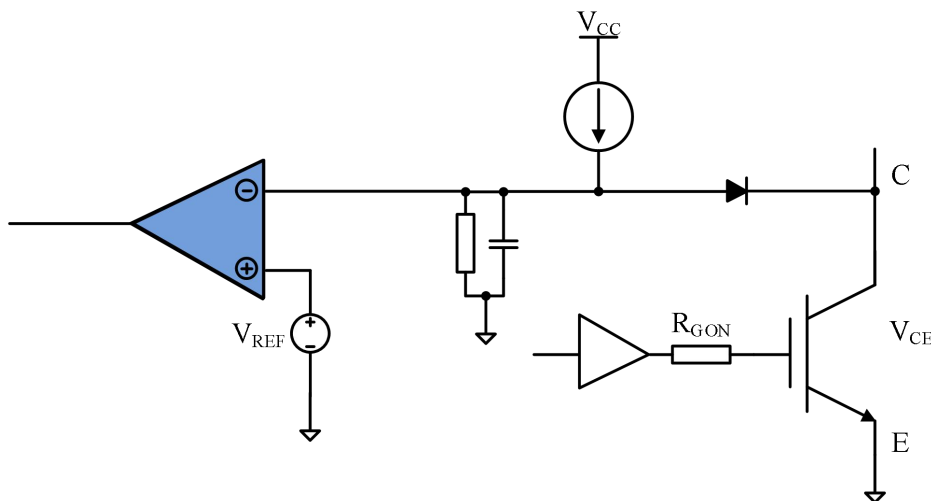
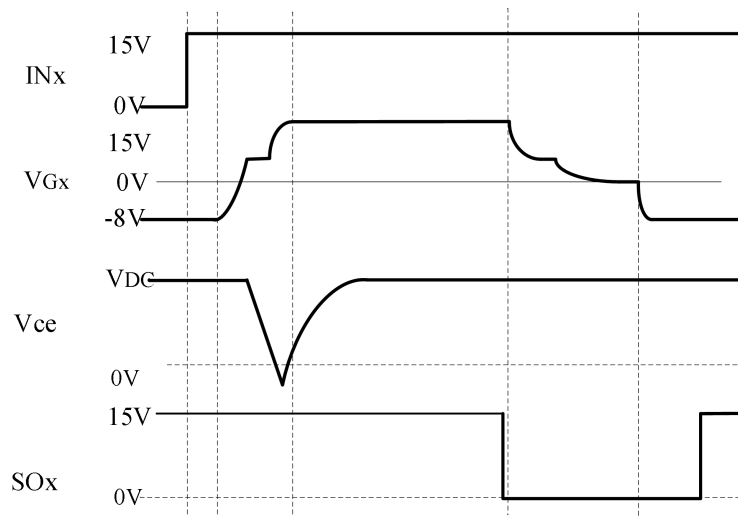

Fig.4 V_{CE} desaturation detection circuit

V_{CE} is detected again after a response time under the turn-on state (refer to **Fig.4**) to determine the short-circuit condition. If this voltage is higher than the preset threshold V_{th} , the gate driver determines that the IGBT has a short-circuit and sends a fault signal to the corresponding fault fibre-optic. At the same time, soft shut down is performed to turn off the IGBT slowly, the IGBT remains in the turn-off state (cut-off), and the fault fibre-optic outputs the fault status, and the fault blocking time lasts for 80ms.

Note: The desaturation detection function is only used for short-circuit protection and cannot provide over-current protection.



5. Soft Shut Down

When IGBT desaturation occurs, V_{CE} reaches the bus voltage. At the same time, the IC will reach 4 times of the rated current or even more and the di/dt at the turn-off time will form a very high voltage spike on the parasitic inductance, which will easily damage the IGBT.

When IGBT desaturation is triggered, the digital core will detect and trigger soft shut down to turn off the IGBT, within 10 μ s, the IGBT is gradually turned down by slowly lowering the gate voltage V_{ge} , which effectively reduces the di/dt , and then reduces the voltage spike at the turn-off moment.

Thus, the short-circuit protection of IGBT is achieved.

6. Active Clamping

Active clamping partially turns the IGBT on when the voltage between the collector and emitter exceeds a preset threshold, thereby suppressing the collector-emitter voltage of the IGBT, which is operating in the linear region.

The 2FHD0320C feature a basic active clamping and an advanced active clamping function consisting of 6 TVS, can effectively suppresses turn-off overvoltage spike.

7. Intelligent Fault Management

The gate driver detects the operation status of the module in real time, and when the module fails, it uploads the fault status to the host computer through the SOx output, and the 2FHC0320 realizes the fault differentiation by the difference of the pull-down time of the SOx signal (the fault return time).

For more information, see the table below.

Fault type	Short-circuit	Undervoltage(sec.)	Undervoltage(pri.)	Other faults
Fault return time	10ms	20ms	40ms	80ms

Technical Support

Firstack's professional team will provide you with business consultation, technical support, product selection, price, lead time and other related information, and guarantee to answer your questions within 48 hours.

Legal Disclaimer

The instruction manual provides a detailed description of the product but does not commit to providing specific parameters regarding the delivery, performance, or applicability of the product.

This document does not offer any express or implied warranties or guarantees.

Firstack reserves the right to modify technical data and product specifications at any time without prior notice. The general delivery terms and conditions of Firstack apply.

Company Information

Tel: +86-571 8817 2737

Fax: +86-571 8817 3973

Website: www.firstack.com

Email: fsales@firstack.com

Address: 4-5/F, Building/5, Xizi Wisdom Industrial Park, No.1279 Tongxie Road, Hangzhou, China